



117 Series

Type H117 (Pressure Switch)

Type H117K (Differential Pressure Switch)

Installation and Operation Instructions

Please read all instructional literature carefully and thoroughly before starting.
Refer to the final page for the Warranty.

GENERAL



MISUSE OF THIS PRODUCT MAY CAUSE EXPLOSION AND PERSONAL INJURY. THESE INSTRUCTIONS MUST BE THOROUGHLY READ AND UNDERSTOOD BEFORE DEVICE IS INSTALLED.



PRIOR TO INSTALLATION, CHECK THE WETTED PARTS MATERIAL FOR COMPATIBILITY TO THE PROCESS MEDIA.

Cert number	20190829-E40857
Applicable Area	North America
Markings	Class I, Div. 2, Groups A, B, C and D; Class II, Div. 2, Group F and G, enclosure Type 4X
Applicable Standards	ANSI/ISA 12.12.01, UL 508; C22.2 No. 14, C22.2 No. 213

Cert number	DEMKO 11 ATEX 1105261X
Applicable Area	Europe (EU)
Markings	II 1 G Ex ia IIC T6 Ga
Applicable Standards	EN IEC 60079-0; EN 60079-11

Cert number	IECEx UL 14.0075X
Applicable Area	International
Markings	Ex ia IIC T6 Ga -50°C ≤ Tamb ≤ +60°C
Applicable Standards	IEC 60079-0; IEC 60079-11



117 SERIES FOR USE IN CLASS I, DIV. 2, GROUPS A, B, C AND D; CLASS II, DIV. 2, GROUPS F AND G; CLASS III; OR NON-HAZARDOUS LOCATIONS ONLY. ENCLOSURE TYPE 4X, IP66. AMBIENT TEMPERATURE RANGE -50°C (-58°F) TO 71°C (160°F).



ATEX AND IEC SPECIFIC CONDITIONS OF USE: ENCLOSURE CONTAINS ALUMINUM. CARE MUST BE TAKEN TO AVOID IGNITION HAZARD DUE TO IMPACT OR FRICTION.



THIS PRODUCT DOES NOT HAVE ANY FIELD REPLACEABLE PARTS. ANY SUBSTITUTION OF COMPONENTS SHALL INVALIDATE AGENCY CERTIFICATION(S), AND IMPAIR SUITABILITY FOR CLASS I, DIV. 2 LOCATION.

The 117 series pressure and differential pressure switch utilizes a bellows or diaphragm sensor to detect a pressure change.

The response, at a pre-determined set point, actuates a SPDT or DPDT snap-acting switch, converting the pressure signal into an electrical signal. Control set point may be varied by turning the internal adjustment hex (see Adjustment-Part II).



PROOF PRESSURE* LIMITS STATED IN THE LITERATURE AND ON NAMEPLATES MUST NEVER BE EXCEEDED, EVEN BY SURGES IN THE SYSTEM. OCCASIONAL OPERATION OF UNIT UP TO PROOF PRESSURE IS ACCEPTABLE (E.G. START-UP, TESTING). EXCESSIVE CYCLING AT MAXIMUM PRESSURE LIMITS COULD REDUCE SENSOR LIFE. CONTINUOUS OPERATION SHOULD NOT EXCEED THE DESIGNATED OVER RANGE OR WORKING PRESSURE RANGE ***.**

* Proof Pressure - the maximum pressure to which a pressure sensor may be occasionally subjected, which causes no permanent damage (e.g., start-up, testing). The unit may require re-gapping.

** Over Range Pressure - the maximum pressure to which a pressure sensor may be continuously subjected without causing damage and maintaining set point repeatability.

*** Working Pressure Range - the pressure range in which two opposing sensors can be safely operated and still maintain set point provided the difference in pressure between the low and high sides does not exceed the designated adjustable range.



DEVICE MUST NOT BE ALTERED OR MODIFIED AFTER SHIPMENT. CONSULT UE IF DEVICE MODIFICATION IS NECESSARY.

Please refer to product datasheet at www.ueonline.com for product specifications. Date code format on nameplate is "YYWW" for year and week.

Part I - Installation



- Adjustable Wrench
- Screwdriver
- Hammer (for alternate wire knockouts)

Mounting



INSTALL DEVICE WHERE SHOCK, VIBRATION AND TEMPERATURE FLUCTUATIONS ARE MINIMAL. DO NOT INSTALL DEVICE IN AMBIENT TEMPERATURES THAT EXCEED PUBLISHED LIMITS ON THE NAMEPLATE.

DEVICE CAN BE MOUNTED IN ANY ORIENTATION BUT VERTICAL MOUNTING IS RECOMMENDED TO PREVENT MOISTURE FROM ENTERING THE ENCLOSURE.

CONSIDER THE USE OF A PRESSURE SNUBBER IF SEVERE PRESSURE SURGES ARE EXPECTED.

FOR PRESSURE MODELS, MOUNT VIA PRESSURE CONNECTION. ALWAYS USE A WRENCH ON PRESSURE CONNECTION HEX. DO NOT TIGHTEN BY TURNING THE ENCLOSURE AS THIS WILL DAMAGE THE SENSOR AND WEAKEN WELDED JOINTS.

FOR DIFFERENTIAL PRESSURE MODELS, MOUNT USING A WRENCH ON LOW AND HIGH SIDE PRESSURE CONNECTION HEX OR MOUNT AGAINST A RIGID SUPPORT THEN CONNECT LOW AND HIGH PRESSURE PORTS.

Controls may be mounted and operated in any position. They may be surface mounted via the two mounting ears on either side of the enclosure, or directly to a rigid pipe by using the pressure connection. Low pressure and differential pressure units, models 520-535, 540-543, 544-548, are also available with an optional surface mounting bracket. Should the control be installed where condensation is expected, vertical mounting is recommended as a means of keeping water away from switch terminals.

Wiring

DISCONNECT ALL SUPPLY CIRCUITS BEFORE WIRING DEVICE. WIRE DEVICE IN ACCORDANCE WITH LOCAL AND NATIONAL ELECTRICAL CODES. MAXIMUM RECOMMENDED WIRE SIZE IS 14 AWG AND RECOMMENDED TIGHTENING TORQUE FOR FIELD WIRING TERMINALS IS 7 TO 17 IN-LBS.

DO NOT EXCEED ELECTRICAL RATINGS LISTED ON NAMEPLATE. OVERLOAD ON A SWITCH CAN CAUSE FAILURE, EVEN ON THE FIRST CYCLE.

ENSURE ELECTRICAL CONDUIT ENTRIES ARE PROPERLY SEALED TO PREVENT MOISTURE ENTRY.

1 Remove the two screws retaining the cover and cover gasket.

2 A 1/2" NPT conduit connection is provided on the left hand side of the enclosure. Two cast-in 7/8" diameter knockouts for electrical conduit are located on the side and back of enclosure (see dimensional drawings). These can easily be knocked out by placing a blade of a screwdriver in groove and tapping sharply with a hammer. The terminal block terminals are clearly labeled "Common", "Normally Open" and "Normally Closed".

For optional switches supplied with leadwires, the following color coding applies:

	SPDT		DPDT	
		Circuit 1	Circuit 2	
Common	Violet	Violet	Yellow	
Normally Closed	Black	Black	Red	
Normally Open	Blue	Blue	Orange	

A grounding screw and clamp (cast in symbol) is provided which meets a 35 lb. pull test. Keep the wire as short as possible to prevent interference with the plunger.

Part II - Adjustments

• 5/8" Open End Wrench

ALL MODELS HAVE A TWO-PIECE ADJUSTABLE PLUNGER (SEE FIGURE 1). THIS FEATURE IS CHARACTERIZED BY A 3/16" HEX SCREW INSTALLED IN THE 1/4" HEX PLUNGER. FOLLOW THE SET-POINT PROCEDURE BELOW TO AVOID DISTURBING THE GAPPING. GAPPING IS FACTORY-SET AND CRITICAL TO THE FUNCTION OF THE SWITCH. THE GAPPING PROCEDURE SHOULD ONLY BE PERFORMED IF THE PLUNGER WAS ACCIDENTALLY ADJUSTED.

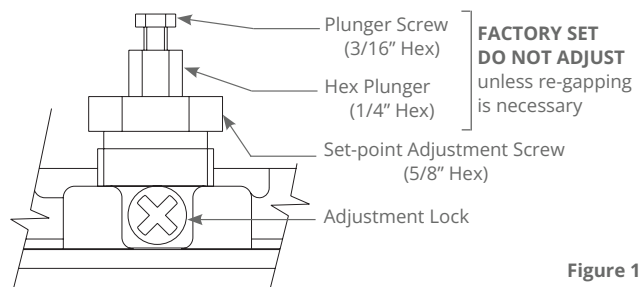

Figure 1

For set point adjustments and recalibration, connect control to a calibrated pressure source.

1 Remove cover.

2 Loosen Phillips screw adjustment lock. Adjust set point by turning 5/8" hex adjustment screw clockwise (left) to raise set point, or counter clockwise (right) to lower set point. Tension on adjustment screw can be increased by tightening adjustment lock onto it. (See Figure 1). Controls include uncalibrated reference scales for high, low or mid range settings. When making adjustments, do not exceed the proof pressure rating on nameplate as this may cause a shift in set point.

NOTE: Models 190-194 and 490-494 (welded stainless steel diaphragms). These models are application sensitive. For rising pressure applications, set point should be adjusted from low pressure up to set point.

For falling pressure applications set point should be adjusted from high pressure down to set point. Wide pressure cycling above and below set point can cause control band shift.

AFTER COMPLETING SETTING ADJUSTMENT, BE SURE TO REINSTALL ENCLOSURE COVER.

Re-Gapping Procedure (refer to Figure 1)

• 5/8" Open End Wrench
• 3/6" Open End Wrench
• 1/4" Open End Wrench



GAPPING IS FACTORY-SET AND CRITICAL TO THE FUNCTION OF THE SWITCH. THIS PROCEDURE SHOULD ONLY BE PERFORMED IF THE PLUNGER HAS ACCIDENTALLY BEEN ADJUSTED.

- 1 Loosen adjustment lock.
- 2 Turn 5/8" hex adjustment screw clockwise (left), to approximately mid range. This puts a load on the sensor and exposes the plunger flats.
- 3 Using a 1/4" wrench on the plunger and a 3/16" wrench on the plunger hex screw, turn hex screw counter-clockwise (right) from plunger until switch actuates. If switch is already actuated, turn plunger hex screw clockwise (left), until switch deactuates. Turn hex screw clockwise (left) from this point. (See Table 1 for Flats and approximate Gap.)
- 4 Check set according to Part II Adjustments.
- 5 Connect wires and replace cover securely.

Models	Flats	Approx. Gap
171-174	2 to 2 1/2	.0085 to .0105"
183-194	1 to 1 1/2	.004 to .006"
483-494	1 to 1 1/2	.004 to .006"
358-376	5 to 6	.020 to .025"
700-706	3 1/2 to 4	.014 to .017"
521-525	2 to 2 1/2	.0085 to .0105"
15737	5 to 6	.020 to .025
531-535	2 to 2 1/2	.0085 to .0105"
540-548	2 to 2 1/2	.0085 to .0105"
565-567	1 to 1 1/2	.004 to .006"

Table 1

Recommended Practices

- A redundant device is necessary for applications where damage to the primary device could endanger life, limb or property. A high or low limit switch is necessary for applications where a dangerous runaway condition could result.
- Monitor operation to observe warning signs of possible damage to device, such as drift in set point or faulty display. Check device immediately.
- Preventative maintenance and periodic testing is necessary for critical applications where damage could endanger property or personnel.

Part III - Dimensions

All dimensions stated in inches (millimeters)
Dimensional drawings for all models may be found at www.ueonline.com

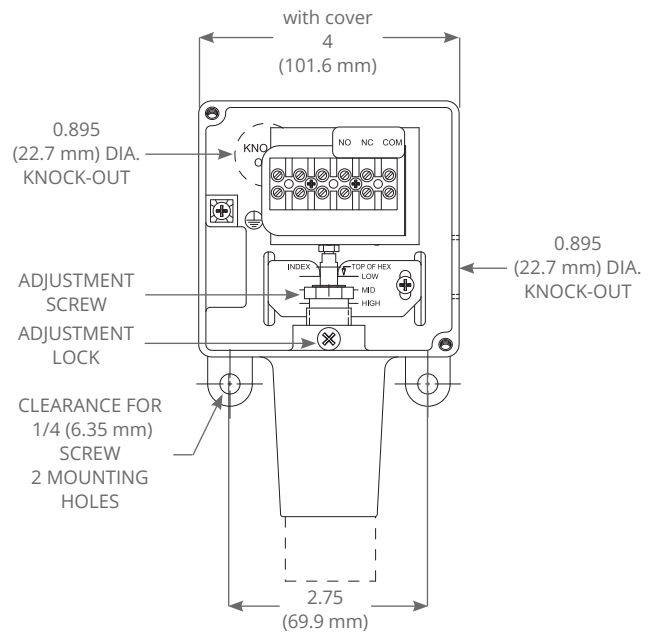
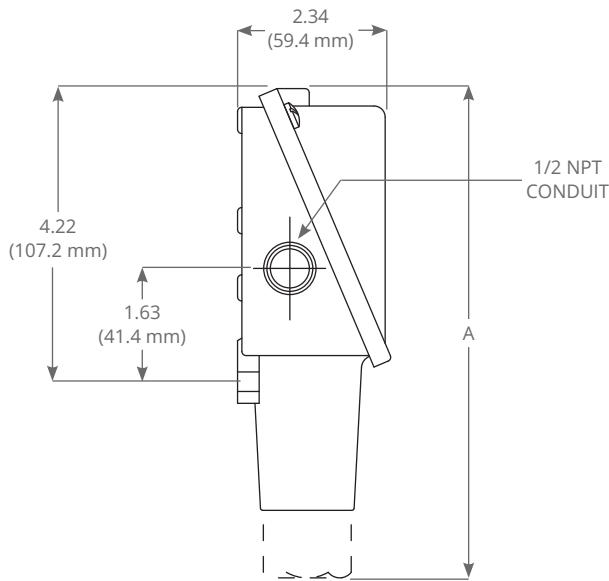

Cover removed in front view

Dimension A			
Models	Inches	mm	NPT (Inches)
Pressure			
171-174	7.63	193.8	1/2
183-186, 483-486	7.56	192.0	1/2
188-189, 488-489, 190-194, 490-494	6.63	168.4	1/2
218	6.56	166.6	1/4
358-376	7.00	177.8	1/4
520-525	8.44	214.4	1/2
530-535	8.00	203.2	1/2
565-567	6.63	168.4	1 1/2" Sanitary Fitting
700-706	6.63	168.4	1/4

Dimension A			
Models	Inches	mm	NPT (Inches)
Differential Pressure			
540-543	8.47	215.1	1/8
544-548	8.53	216.7	1/8

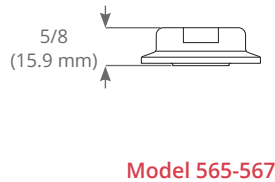
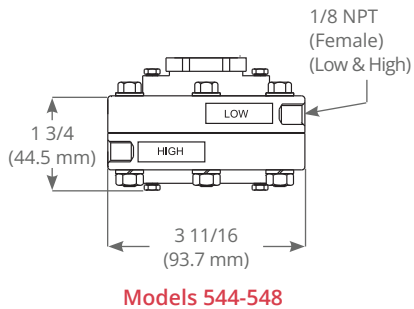
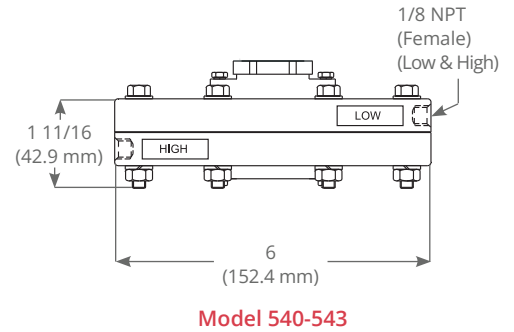
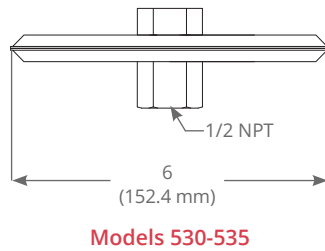
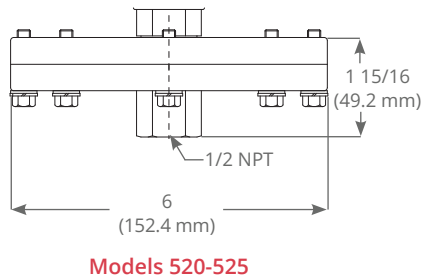
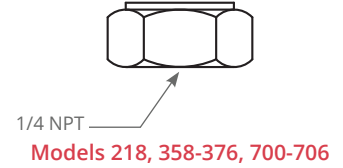
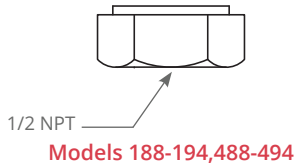
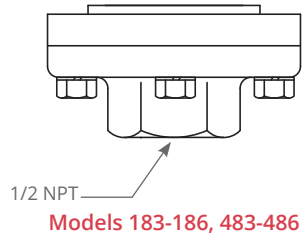
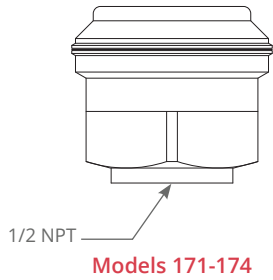

French Warnings Translations

Page	Warning Text	Texte d'Avertissement
1	MISUSE OF THIS PRODUCT MAY CAUSE EXPLOSION AND PERSONAL INJURY. THESE INSTRUCTIONS MUST BE THOROUGHLY READ AND UNDERSTOOD BEFORE UNIT IS INSTALLED.	Une mauvaise utilisation de cet appareil peut provoquer une explosion et/ou des blessures. Ces consignes doivent être lues attentivement et bien comprises avant l'installation de l'appareil.
1	117 SERIES FOR USE IN CLASS I, DIV. 2, GROUPS A, B, C AND D; CLASS II, DIV. 2, GROUPS F AND G; CLASS III; OR NON-HAZARDOUS LOCATIONS ONLY. ENCLOSURE TYPE 4X, IP66. AMBIENT TEMPERATURE RANGE -50°C (-58°F) TO 71°C (160°F).	Le 117 Series est adapté à une utilisation dans les lieux de Classe I, Division 2, de Groupes A, B, C et D ; Classe II, Division 2, Groupes F et G ; Classe III; ou non-dangereux. Boîtier de type 4X, IP66. Plage de température ambiante -50°C (-58°F) à 71°C (160°F).
1	ATEX AND IEC SPECIFIC CONDITIONS OF USE: ENCLOSURE CONTAINS ALUMINIUM. CARE MUST BE TAKEN TO AVOID IGNITION HAZARD DUE TO IMPACT OR FRICTION.	Conditions spécifiques d'utilisation ATEX et IEC: Le boîtier contient de l'aluminium. Des précautions doivent être prises pour éviter tout risque d'inflammation dû à un choc ou à un frottement.
1	THIS PRODUCT DOES NOT HAVE ANY FIELD REPLACEABLE PARTS. ANY SUBSTITUTION OF COMPONENTS SHALL INVALIDATE AGENCY CERTIFICATION(S), AND IMPAIR SUITABILITY FOR CLASS I, DIV. 2 LOCATION.	Aucun composant de cet appareil ne peut être remplacé sur le terrain. Toute substitution de composant invalidera les approbations et certifications données par un tiers et compromettra l'utilisation dans un lieu de Classe I, Division 2.
1	INSTALL DEVICE WHERE SHOCK, VIBRATION AND TEMPERATURE FLUCTUATIONS ARE MINIMAL. DO NOT INSTALL DEVICE IN AMBIENT TEMPERATURES THAT EXCEED PUBLISHED LIMITS ON THE NAMEPLATE.	Installer l'appareil dans un endroit où les chocs, les vibrations et les variations de température sont minimales. Ne pas installer l'appareil dans un lieu où les températures ambiantes dépassent les limites indiquées sur la plaque signalétique de l'appareil.
2	DISCONNECT ALL SUPPLY CIRCUITS BEFORE WIRING UNIT. WIRE UNITS ACCORDING TO NATIONAL AND LOCAL ELECTRICAL CODES. MAXIMUM RECOMMENDED WIRE SIZE IS 14 AWG. THE RECOMMENDED TIGHTENING TORQUE FOR FIELD WIRING TERMINALS IS 7 TO 17 IN-LBS.	Avant le branchement de l'appareil, déconnecter l'installation sur laquelle l'appareil doit être monté. Réaliser le branchement électrique selon les codes électriques nationaux et locaux. Le diamètre maximal recommandé pour les fils est de 14 AWG. Le couple de serrage pour la borne de raccordement est de 7 à 17 IN-LBS.
2	DO NOT EXCEED ELECTRICAL RATINGS LISTED ON NAMEPLATE. OVERLOAD ON A SWITCH CAN CAUSE FAILURE, EVEN ON THE FIRST CYCLE.	Les seuils électriques indiqués sur la plaque signalétique ne doivent jamais être dépassés. La surtension peut causer une panne de l'appareil dès les premier cycle.

LIMITED WARRANTY

Seller warrants that the device hereby purchased is, upon delivery, free from defects in material and workmanship and that any such device which is found to be defective in such workmanship or material will be repaired or replaced by Seller (Ex-works, Factory, Watertown, Massachusetts. INCOTERMS); provided, however, that this warranty applies only to device found to be so defective within a period of 24 months from the date of manufacture by the Seller. Seller shall not be obligated under this warranty for alleged defects which examination discloses are due to tampering, misuse, neglect, improper storage, and in any case where devices are disassembled by anyone other than authorized Seller's representatives. EXCEPT FOR THE LIMITED WARRANTY OF REPAIR AND REPLACEMENT STATED ABOVE, SELLER DISCLAIMS ALL WARRANTIES WHATSOEVER WITH RESPECT TO THE DEVICE, INCLUDING ALL IMPLIED WARRANTIES OF MERCHANTABILITY OR FITNESS FOR ANY PARTICULAR PURPOSE.

LIMITATION OF SELLER'S LIABILITY

Seller's liability to Buyer for any loss or claim, including liability incurred in connection with (i) breach of any warranty whatsoever, expressed or implied, (ii) a breach of contract, (iii) a negligent act or acts (or negligent failure to act) committed by Seller, or (iv) an act for which strict liability will be inputted to seller, is limited to the "limited warranty" of repair and/or replacement as so stated in our warranty of device. In no event shall the Seller be liable for any special, indirect, consequential or other damages of a like general nature, including, without limitation, loss of profits or production, or loss or expenses of any nature incurred by the buyer or any third party.

UE specifications subject to change without notice.



180 Dexter Avenue
Watertown, MA 02472 - USA
Telephone: 617 926-1000 - Fax: 617 926-2568
www.ueonline.com

FOR A LIST OF OUR INTERNATIONAL AND
DOMESTIC REGIONAL SALES OFFICES
PLEASE VISIT OUR WEBPAGE
WWW.UEONLINE.COM