



Style 84

Explosion-Proof RTD and Thermocouple
Assemblies with Welded Process Connection

Installation and Operation Instructions

Please read all instructional literature carefully and thoroughly before starting.
Refer to the final page for the Warranty.

GENERAL

! MISUSE OF THIS PRODUCT MAY CAUSE EXPLOSION AND PERSONAL INJURY. THESE INSTRUCTIONS MUST BE THOROUGHLY READ AND UNDERSTOOD BEFORE UNIT IS INSTALLED.

! STYLE 84 FOR USE IN HAZARDOUS LOCATIONS PER BELOW.

Cert Number	FM24US0225X FM24CA0059X
Applicable Area	North America
Markings	Class I Div 1 Groups B, C, D Class II, Div 1 Groups E, F, G Class III -40 °C ≤ Ta ≤ +85 °C Type 4X, IP66/68 1m, 1hr

Cert Number	FM24ATEX0030X
Applicable Area	Europe
Markings	⊕ II 2 G Ex db IIC T6...T1 Gb T5... T1 (Ta= -20 °C to 85 °C) T6 (Ta= -20 °C to 80 °C) ⊕ II 2 D Ex tb IIIC T90°C...T125°C Db -40 °C ≤ Ta ≤ +85 °C IP66/68 1m, 1hr

Cert Number	IECEx FMG 24.0032X
Applicable Area	International
Markings	Ex db IIC T6...T1 Gb T5... T1 (Ta= -20 °C to 85 °C) T6 (Ta= -20 °C to 80 °C) Ex tb IIIC T90°C...T125°C Db -40 °C ≤ Ta ≤ +85 °C IP66/68 1m, 1hr

! THIS PRODUCT DOES NOT HAVE ANY FIELD REPLACEABLE PARTS. ANY SUBSTITUTION OF COMPONENTS WILL INVALIDATE THIRD-PARTY ISSUED APPROVALS AND CERTIFICATIONS, AND MAY IMPAIR SUITABILITY FOR CLASS I, DIVISION 1 LOCATION.

i MAX. TEMPERATURE* LIMITS MUST NEVER BE EXCEEDED, EVEN BY SURGES IN THE SYSTEM. OCCASIONAL OPERATION OF UNIT UP TO MAX. TEMPERATURE IS ACCEPTABLE, E.G., START-UP AND TESTING. EXCESSIVE CYCLING AT MAXIMUM TEMPERATURE LIMIT COULD REDUCE SENSOR LIFE. CONTINUOUS OPERATION SHOULD NOT EXCEED THE DESIGNATED TEMPERATURE RANGE.

* Maximum Temperature - the highest temperature to which a sensing element may be occasionally operated without adversely affecting accuracy and life.

The maximum temperature will dictate which temperature class (T-Code) the unit is rated for in hazardous location applications. The T-Code is based on the process temperature at the boundary point to the hazardous area, and should always be considered before installation. See T-Code values per Table 1 and Table 2 (see page 2).

i DEVICE MUST NOT BE ALTERED OR MODIFIED AFTER SHIPMENT. CONSULT UE IF MODIFICATION IS NECESSARY.

Style 84 temperature sensors use either an RTD or thermocouple element to sense and convert temperature to an electrical signal.

RTD assemblies contain a platinum element with an output conforming to the 100-ohm DIN curve (0.00385 alpha).

Thermocouples conform to the ANSI standard calibrations, as noted in the wiring diagrams.

All assemblies feature a flame-proof terminal head with terminal block. The sheath is welded to the process fitting for direct immersion in the process.

Part I - Installation

Mounting



- Adjustable wrench



INSTALL DEVICE WHERE SHOCK, VIBRATION AND TEMPERATURE FLUCTUATIONS ARE MINIMAL. DO NOT INSTALL DEVICE IN AMBIENT TEMPERATURES THAT EXCEED PUBLISHED LIMITS ON THE NAMEPLATE.



DEVICE SHOULD BE MOUNTED TO PREVENT MOISTURE FROM ENTERING THE ENCLOSURE. VERTICAL MOUNTING IS RECOMMENDED.

- Prepare the process fitting with TFE tape wrap or other sealing material.
- Screw the fitting into the matching NPT fitting, using a wrench on the hex flats of the sensor assembly.
- Install electrical conduit.
- Verify that the process connection is sealed.

Wiring



- Small phillips-head screwdriver



DISCONNECT ALL SUPPLY CIRCUITS BEFORE WIRING UNIT. WIRE UNITS ACCORDING TO NATIONAL AND LOCAL ELECTRICAL CODES. THE WIRES SHOULD BE PROTECTED AGAINST MECHANICAL DAMAGE BY USE OF A CONDUIT OR OTHER SUITABLE MEANS.

- Using the wiring diagrams on page 3, connect signal wiring appropriate to the sensor.
 - For thermocouples, use an extension-wire that matches the sensor's calibration.
 - For an RTD, use twisted, shielded conductors with the same number of conductors as the sensor.
- Tighten the cover.

Specific Conditions of Use

- Flameproof joints are not intended for repair.
- Appropriate cable, glands, and conduit seals need to be suitable for a temperature of 5 °C greater than the maximum specified ambient temperature for location where installed.
- Potential Electrostatic Charging Hazard. Avoid Installation that could cause electrostatic build-up and only clean with a damp cloth.
- Refer to Table 1 and Table 2 for the applicable Temperature Class / Maximum Surface Temperature rating assigned according to assigned, allowed ambient and process temperature ranges.
- The RTD/Thermocouple sensor assemblies require the use of a suitably rated thermowell installed for the end use application if the process pressure rating is higher than 7.25 psig.

Temp. Class (T-Code) Ex db	Ambient Temperature Range (°C)	Process Temperature Range (°C)
T6	-20 to +80	-20 to +85
T5	-20 to +85	-20 to +100
T4	-20 to +85	-20 to +135
T3	-20 to +85	-20 to +200
T2	-20 to +85	-20 to +300
T1	-20 to +85	-20 to +450

Table 1

Maximum Surface Temp. DUST	Ambient Temperature Range (°C)	Process Temperature Range (°C)
T90C	-40 to +85	-20 to +85
T100C	-40 to +85	-20 to +100
T125C	-40 to +85	-20 to +125

Table 2

Recommended Practices

- A redundant device is necessary for applications where damage to the primary device could endanger life, limb or property. A high or low limit switch is necessary for applications where a dangerous runaway condition could result.
- Monitor operation to observe warning signs of possible damage to device, such as drift in reading. Check device immediately.
- Preventative maintenance and periodic testing is necessary for critical applications where damage could endanger property or personnel.

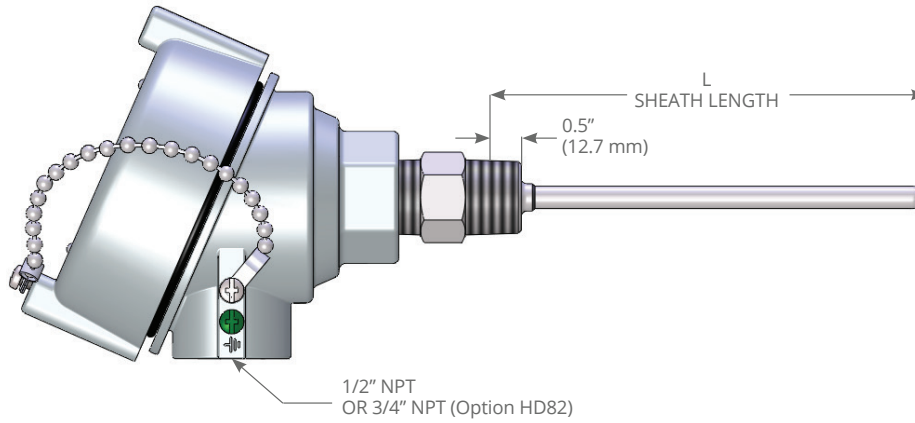

RTD

SINGLE 2 WIRE RTD
(RTP6 WIRING DIAGRAM)

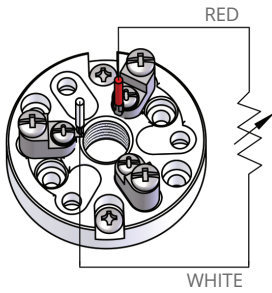

SINGLE 3 WIRE RTD
(RTP1 WIRING DIAGRAM)

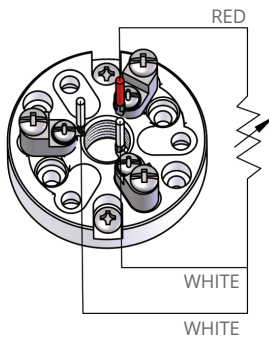

SINGLE 4 WIRE RTD
(RTP7 WIRING DIAGRAM)

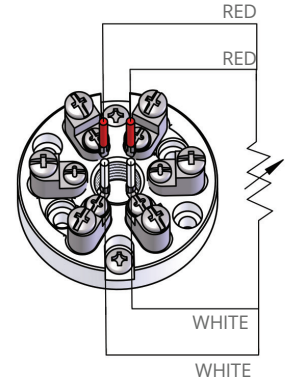

DUAL 2 WIRE RTD
(DRTP1 WIRING DIAGRAM)

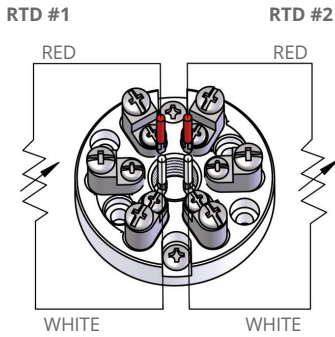

DUAL 3 WIRE RTD
(DRTP1 WIRING DIAGRAM)

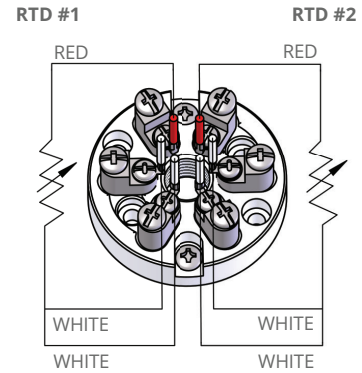

Thermocouple

SINGLE JUNCTION K CALIBRATION
WIRING DIAGRAM

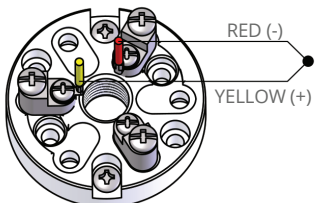

DUAL JUNCTION K CALIBRATION
WIRING DIAGRAM

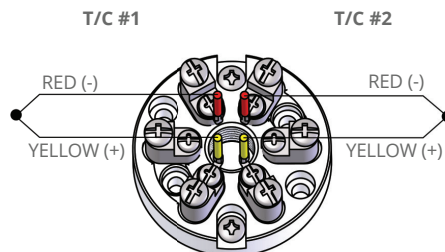

Calibration	Positive (+) Lead Material (color)	Negative (-) Lead Material (color)
E	Chromel (Purple)	Constantan (Red)
J	* Iron (White)	Constantan (Red)
K	Chromel (Yellow)	*Alumel (Red)
T	Copper (Blue)	Constantan (Red)

* Magnetic

French Warnings Translations

Pg	Warning Text	Texte d'Avertissement
1	MISUSE OF THIS PRODUCT MAY CAUSE EXPLOSION AND PERSONAL INJURY. THESE INSTRUCTIONS MUST BE THOROUGHLY READ AND UNDERSTOOD BEFORE UNIT IS INSTALLED.	Une mauvaise utilisation de cet appareil peut provoquer une explosion et/ou des blessures. Ces consignes doivent être lues attentivement et bien comprises avant l'installation de l'appareil.
1	THIS PRODUCT DOES NOT HAVE ANY FIELD REPLACEABLE PARTS. ANY SUBSTITUTION OF COMPONENTS WILL INVALIDATE THIRD-PARTY ISSUED APPROVALS AND CERTIFICATIONS, AND MAY IMPAIR SUITABILITY FOR CLASS I, DIVISION 1 LOCATION.	Aucun composant de cet appareil ne peut être remplacé sur le terrain. Toute substitution de composant invalidera les approbations et certifications données par un tiers et compromettra l'utilisation dans un lieu de Classe I, Division 1.
1	INSTALL DEVICE WHERE SHOCK, VIBRATION AND TEMPERATURE FLUCTUATIONS ARE MINIMAL. DO NOT INSTALL DEVICE IN AMBIENT TEMPERATURES THAT EXCEED PUBLISHED LIMITS ON THE NAMEPLATE.	Installer l'appareil dans un endroit où les chocs, les vibrations et les variations de température sont minimales. Ne pas installer l'appareil dans un lieu où les températures ambiantes dépassent les limites indiquées sur la plaque signalétique de l'appareil.
2	DISCONNECT ALL SUPPLY CIRCUITS BEFORE WIRING DEVICE. WIRE DEVICE IN ACCORDANCE WITH LOCAL AND NATIONAL ELECTRICAL CODES. WIRES SHOULD BE PROTECTED AGAINST MECHANICAL DAMAGE BY USE OF A CONDUIT OR OTHER SUITABLE MEANS.	Avant le branchement de l'appareil, déconnecter l'installation sur laquelle l'appareil doit être monté. Réaliser le branchement électrique selon les codes électriques nationaux et locaux. Le diamètre maximal recommandé pour les fils est de 14 AWG. Le couple de serrage pour la borne de raccordement est de 7 à 17 IN-LBS.

TERMS AND CONDITIONS OF SALE



UE specifications subject to change without notice.



180 Dexter Avenue
Watertown, MA 02472 - USA
Telephone: 617 926-1000 - Fax: 617 926-2568
www.ueonline.com

FOR A LIST OF OUR INTERNATIONAL AND
DOMESTIC REGIONAL SALES OFFICES
PLEASE VISIT OUR WEBPAGE
WWW.UEONLINE.COM