



VANGUARD



WirelessHART® Toxic & Combustible Gas Detector
P/N: TCD50

WirelessHART

Installation and Operation Instructions

Please read all instructional literature carefully and thoroughly before starting.

Refer to the final page for the Warranty.

United Electric Controls provides these installation and maintenance instructions for the UE Vanguard WirelessHART toxic & combustible gas detector solely. The end-user is responsible for maintaining the Vanguard WirelessHART toxic & combustible gas detector in full, operational condition.

! ALL WARNINGS MUST BE THOROUGHLY READ, UNDERSTOOD AND FOLLOWED.

! MISUSE OF THIS DEVICE AND FAILURE TO ADHERE TO ALL WARNINGS COULD RESULT IN:
• THE DEVICE NOT PERFORMING AS INTENDED,
• RISK OF EXPLOSION,
• RISK OF LOSING CONSCIOUSNESS OR DEATH.

The following symbols are used within this document:

- !** International Hazard Warning symbol. Directions require strict adherence.
- ☠** International Toxic Hazard symbol. Exposure may lead to loss of consciousness or death.
- 🔥** International Flammable Material Hazard symbol. Exposure to flammable materials in closed areas may lead to explosion, loss of consciousness or death.
- i** United Electric Controls (UE) warning or recommended practice.

Other documents referenced in the manual:



Datasheet
(TCD-B)



Annex A
(IM_TCD_ANNEX_A)

TABLE OF CONTENTS

1.0 General	
1.1 Device Overview	2
1.2 Device Packaging	2-3
1.3 Device Approvals	3
2.0 Installation	
2.1 Sensor Installation	4
2.2 Battery Installation	4
2.3 Sensor Activation	5
2.4 Network Configuration	6
2.5 Sensor Placement Considerations	7-8
2.6 Sensor Cross Sensitivity	8
2.7 Classified Area Installation	8
2.8 Field Mounting	8-10
2.9 Optional Remote Mount Kit for Sensors	10
2.10 Antenna Placement Considerations	10
3.0 Operation	
3.1 Normal Operation	11
3.2 Sensor Calibration & Bump Test	11-12
3.3 Programming Mode	13-15
4.0 Field Replacement	
4.1 Sensor Replacement	15
4.2 Battery Replacement	15-16
5.0 Troubleshooting Guide	
5.1 Hardware	16
5.2 Wireless Communication	17
6.0 Dimensional Drawings	17
7.0 Nameplates	
7.1 Front Cover Nameplate	18
7.2 Back Cover Nameplate	18
8.0 Warnings French Translations	19

1.0 GENERAL



MISUSE OF THIS DEVICE MAY CAUSE EXPLOSION AND/OR PERSONAL INJURY. THESE INSTRUCTIONS MUST BE THOROUGHLY READ AND UNDERSTOOD PRIOR TO INSTALLATION OF THE DEVICE.



THE END-USER IS RESPONSIBLE FOR MAINTAINING THE DEVICE IN FULL, OPERATIONAL CONDITION.



TO ENSURE PROPER INGRESS PROTECTION, THE FRONT AND REAR COVERS MUST BE INSTALLED, AND FULLY BOTTOMED OUT AGAINST THE BASE ENCLOSURE (I.E., METAL-TO-METAL CONTACT). IT IS RECOMMENDED TO USE A WRENCH OR ANY TOOL ACROSS THE COVER LUGS TO TIGHTEN THE COVERS DOWN.



EXPOSURE TO TOXIC GAS MAY RESULT IN LOSS OF CONSCIOUSNESS OR DEATH. SEE ANNEX A FOR TOXIC GAS SENSOR DETAILS.



COMBUSTIBLE GAS ACCUMULATION IN CLOSED AREAS MAY CAUSE EXPLOSION, AND RESULT IN LOSS OF CONSCIOUSNESS OR DEATH. SEE ANNEX A FOR COMBUSTIBLE GAS SENSOR DETAILS.



AVOID DROPPING THE DEVICE AS LOOSENING OF THE THREADED FLAME-PROOF JOINTS OR PERMANENT DAMAGE MAY OCCUR.



NEW SENSORS MUST BE CALIBRATED AFTER INSTALLATION (SEE SECTION 3.2).



WHEN NOT IN USE, THE DEVICE SHOULD BE STORED IN A CLEAN, DRY AREA AND WITHIN THE TEMPERATURE RANGE LISTED WITHIN THE DEVICE'S ENVIRONMENTAL SPECIFICATIONS.

1.1 Device Overview

The device is an explosion-proof and intrinsically safe, WirelessHART point gas detector used for the detection and monitoring of harmful gases in air. A field-interchangeable gas sensor module (see Figure 2) provides detection of toxic or combustible gas. Gas measurement readings are communicated along with network and battery status (see Figure 1) via a local, digital display, and WirelessHART communication protocol. The device seamlessly integrates with existing supervisory control and data acquisition (SCADA) or asset management (AMS) systems.

Sensor specifications are available online or in Annex A which can be downloaded from www.ueonline.com

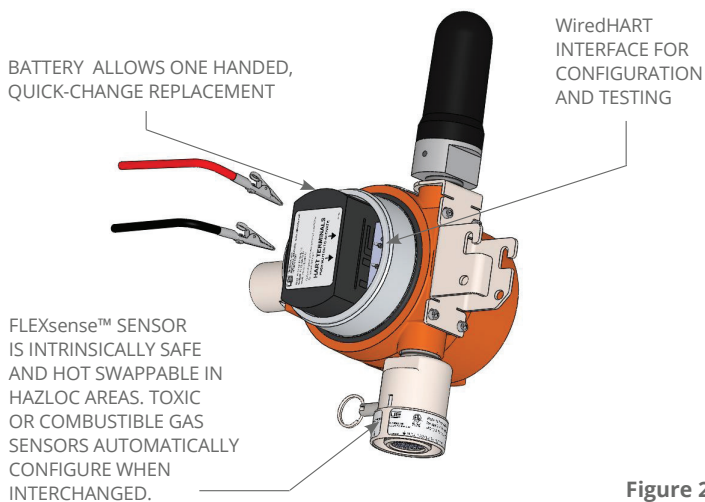
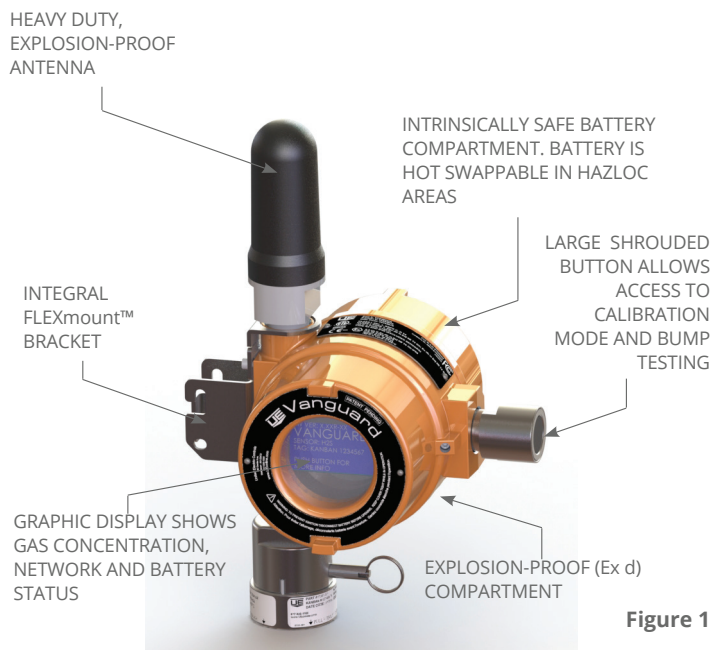

1.2 Device Packaging

The device may be shipped in one of the following two configurations. Please ensure that all items have been received before proceeding with installation and operation.

1. Base unit and mounting bracket kit with toxic or combustible FLEXsense™ sensor (Figure 3 and Figure 4).
2. Base unit and mounting bracket kit only (Figure 3 without sensor and Figure 4).

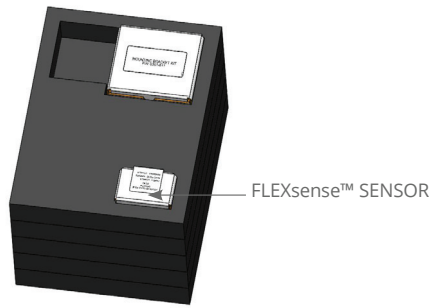

Top foam for packaging

Figure 3

	Global Certification IECEx ETL16.0016X Ex db ia op is [ia] IIB T4 Gb IP66** Tamb: X
	EU Certification ITS 16 ATEX 18474X II 2 (2) G Ex db ia op is [ia] IIB T4 Gb IP66** Tamb: X*
	North American Certification Class I Div. 1, Groups C & D, T4 Class I, Zone 1, AEx db ia op is [ia] IIB T4 Gb Ex db ia op is [ia] IIB T4 Gb Enclosure Type 4X, IP66** Tamb: X*

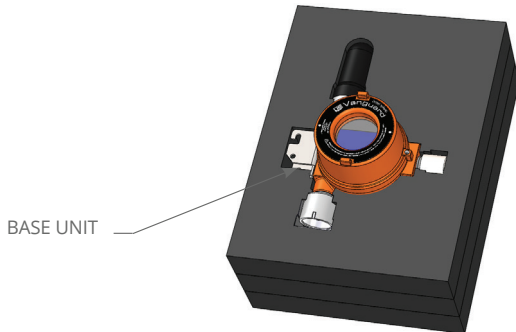

Bottom foam for packaging

Figure 4

Specific Conditions of Use:

- No repair/modification to the flameproof joints is permitted.
- The ambient temperature range rating is based on the configuration (Fitted Gas Sensor): Reference Product Description in Certificate. The Configuration which is based on the fitted Gas Sensor is indicated by the marked code on the Gas Sensor Module Body (Label): Code A or Code B (See Table in Product Description***).

Conforms to:

UL Std. 913, UL Std. 1203
 UL Std. 60079-0, UL Std. 60079-1
 UL Std. 60079-11, UL Std. 61010-1

Certified to:

CAN/CSA Std. C22.2 No. 60079-0
 CAN/CSA Std. C22.2 No. 60079-1
 CAN/CSA Std. C22.2 No. 60079-11
 CAN/CSA Std. C22.2 No. 61010-1-12

See ITS16ATEX18474X for EN Standards.
 See IECEx ETL 16.0016X for IECEx Standards.

Certificates are available for download on the UE website:
www.ueonline.com

* Ambient operating temperature range may vary with sensor type. See datasheet for sensor specifications.

** Enclosure Type 4X and IP66 rating excludes sensor.

*** Refer to EU Type - Examination Certificate



DEVICE IS SHIPPED WITHOUT THE SENSOR OR BATTERY INSTALLED. BOTH MUST BE INSTALLED PRIOR TO USE. SEE SECTION 2.0 INSTALLATION FOR FURTHER INFORMATION.

1.2.1 Sensors

One FLEXsense™ sensor is shipped (but uninstalled) with the base unit (if ordered in that configuration). Additional, spare FLEXsense™ sensors may be ordered and will ship separately.

1.2.2 Battery

The battery pack is shipped separately as it contains lithium. Transportation must comply with special safe transport regulations worldwide.

1.3 Device Approvals



THIS DEVICE IS SUITABLE FOR HAZARDOUS LOCATIONS PER CERTIFICATIONS (SEE BELOW) OR NON-HAZARDOUS LOCATIONS ONLY.



THIS DEVICE MEETS ALL REQUIREMENTS FOR STANDARDS LISTED ON THE CERTIFICATIONS (SEE BELOW).



THE ONLY FIELD REPLACEABLE PARTS ARE THE BATTERY PACK AND FLEXSENSE™ SENSOR. ANY SUBSTITUTION OF COMPONENTS OTHER THAN THE BATTERY AND GAS SENSOR MODULE WILL INVALIDATE THIRD-PARTY ISSUED APPROVALS AND CERTIFICATIONS, AND MAY IMPAIR SUITABILITY FOR HAZARDOUS LOCATIONS.

2.0 INSTALLATION

2.1 Sensor Installation

TO PREVENT IGNITION, ONLY USE SENSORS PROVIDED BY UNITED ELECTRIC CONTROLS.

DO NOT ATTEMPT TO DISASSEMBLE THE SENSOR AS THIS COULD DAMAGE THE SENSOR AND VOID HAZARDOUS LOCATION APPROVALS, AND MANUFACTURER WARRANTY.

SENSORS MUST BE ACTIVATED AFTER INSTALLATION.

ENSURE BASE UNIT HAS A SENSOR INSTALLED AT ALL TIMES WHEN MOUNTED OUTDOORS TO PREVENT DAMAGE TO CONNECTORS DUE TO AMBIENT MOISTURE.

Sensors are packaged fully assembled and require simple installation into the base unit. Toxic sensors are comprised of an electrochemical sensor packaged into a stainless steel housing. Combustible sensors are comprised of an infrared sensor packaged into a stainless steel housing. These are consumable, field replaceable parts (see Section 4.1 Sensor Replacement).

- 1 Remove FLEXsense™ sensor from packaging.
- 2 Retract the sensor locking pin and twist 90 degrees to lock in retracted position.
- 3 Align the locating pins (see Figure 5) on the FLEXsense™ sensor to the keyed positions on the sensor housing (see Figure 6).
- 4 Insert the sensor. A click will be felt and heard, ensuring the sensor has been inserted correctly.
- 5 Twist the sensor locking pin 90 degrees and release to engage the sensor locking pin.

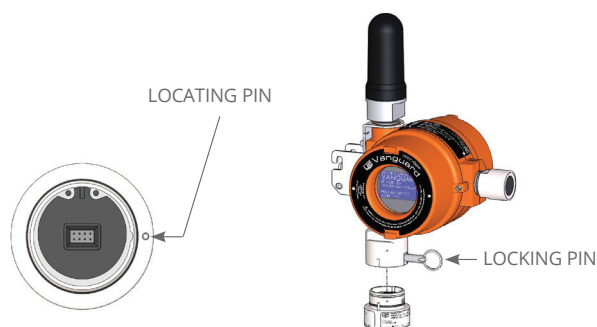

Figure 5

Figure 6

2.2 Battery Installation

TO PREVENT IGNITION, USE ONLY BATTERY PACKS SUPPLIED BY UNITED ELECTRIC CONTROLS.

BATTERY SHOULD BE REMOVED AND STORED WHEN THE DEVICE IS NOT IN USE. DEVICE USES SIGNIFICANTLY MORE POWER WHILE ROAMING.

BATTERIES ARE NOT RECHARGEABLE.

The battery pack contains two Lithium-Thionyl Chloride D size cells, with a nominal output voltage of 7.2V.

NOTE: 7.2V @ 1mA (at 20 °C) Max possible power consumption when starting the device and searching for a network (searching) (see page 6 for details).

- 1 Unscrew the solid, back cover from the intrinsically safe battery compartment and set aside.
- 2 Remove the battery pack from its packaging.
- 3 Align battery pack so connection on the pack lines up with connection in the enclosure.
- 4 Slide the battery pack into the enclosure until it latches in place as shown in Figure 7.

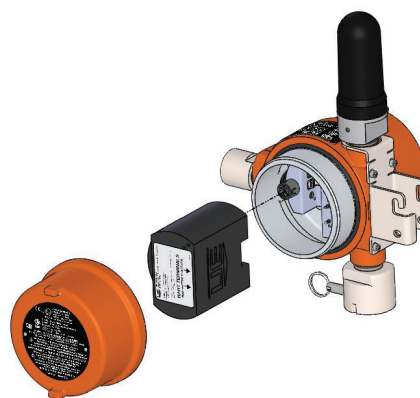

Figure 7

- 5 The device is now powered and will show the word STARTING along with the hardware and software versions on the front panel display while initial boot-up completes (see Figure 8). Allow for a minimum warm-up time of at least the t_{90} of the sensor shown in Annex A or 30 seconds whichever is shorter.

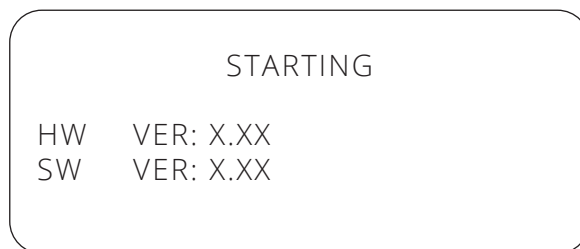

Figure 8

- 6 When hardware and software boot-up is complete, the device will prompt user to activate the installed sensor (see Figure 9).

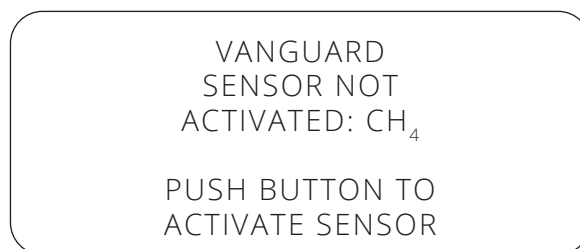

Figure 9

2.3 Sensor Activation

- 1 Push button to activate sensor.
- 2 Once the button is pushed, the base transmitter initializes the sensor activation process. During this activation, the screen in Figure 10 will be displayed. This activation may take up to 2 minutes.



Figure 10

- 3 The device will prompt the user to zero the offset as shown in Figure 11.

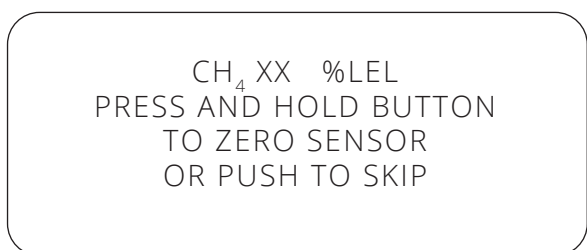

Figure 11

Zero the offset:

Apply dry air or nitrogen to the sensor for a period longer than the sensors response time, then press and hold the calibration button until the display screen in Figure 12 appears. This takes about 10 seconds.

Skip the offset:

Press and release the calibration button to skip the zeroing process and proceed to step 4.



Figure 12

NOTE: To zero the combustible sensor at any time, press and hold the calibration button for 10 seconds. Refer to section 2.3, step 3, to continue sequence.

- 4 Once the sensor initialization process is complete, a "Sensor Active Calibrate New Sensors" message will show (see Figure 13) before automatically returning to home screen (Figure 14).

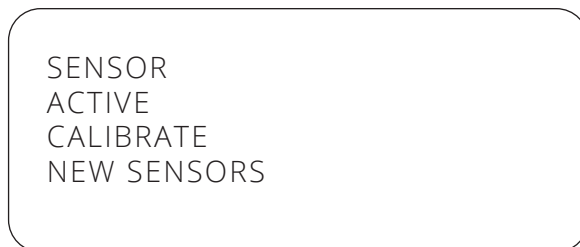

Figure 13

- 5 The sensor is self-configuring with the device and once booted up (see Section 2.4 Network Configuration) will display the proper gas concentration.
- 6 Once activation is done, the front panel display will display the device name, HART long tag, and the software version, along with an instruction to push button to show gas concentration (see Figure 14).

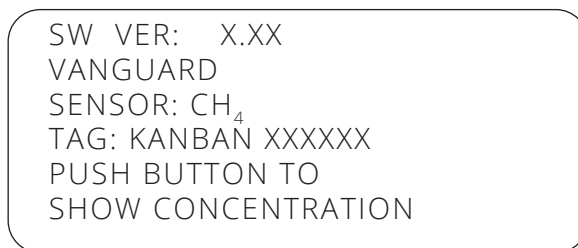

Figure 14

- 7 The device is now ready to be configured for deployment into a WirelessHart network. It is recommended to connect the device to the network immediately after battery installation to maximize battery life. Refer to section 2.4 for network configuration.
- 8 Once device configuration is complete, secure cover onto enclosure by tightening until all threads have been fully engaged to ensure proper ingress protection.

TO ENSURE PROPER INGRESS PROTECTION, THE REAR COVER MUST BE INSTALLED, AND FULLY BOTTOMED OUT AGAINST THE BASE ENCLOSURE (I.E., METAL-TO-METAL CONTACT). IT IS RECOMMENDED TO USE A WRENCH OR ANY TOOL ACROSS THE COVER LUGS TO TIGHTEN THE COVERS DOWN.

2.4 Network Configuration

IT IS RECOMMENDED THAT NETWORK CONFIGURATION BE PERFORMED RIGHT AFTER BATTERY INSTALLATION TO MAXIMIZE BATTERY LIFE.

The device must be configured to communicate over the wireless network. A Network ID and Join Key are required to communicate over the wireless network, and must match the Network ID and Join Key of the wireless gateway and other wireless devices in the network.

This device sends gas concentration information reliably and securely via WirelessHART communication protocol. Configuration can be completed using any HART handheld communicator, or directly into the control system using a HART modem. HART terminals are located inside the intrinsically safe battery compartment and are clearly marked (see Figure 15).

Configuring the gas detection device in the hazardous area requires a suitable, approved intrinsically safe device (such as a handheld communicator, etc.). The entity parameters of the device being connected must be compatible with those of the gas detection device.

Before connecting any device in the hazardous location, the following entity parameters must be verified:

$$\begin{array}{ll} U_o \leq U_i \text{ prog} & L_o \geq L_i \text{ prog} \\ I_o \leq I_i \text{ prog} & U_i \geq U_o \text{ prog} \\ P_o \leq P_i \text{ prog} & I_i \geq I_o \text{ prog} \\ C_o \geq C_i \text{ prog} & \end{array}$$

Gas Detector Intrinsic Safety Entity Parameters:

$$U_o = 4.935V; I_o = 0.179A; P_o = 0.22W; C_o = 1000 \mu F; L_o = 10mH$$

$$U_i = 3.8V; I_i = 64\mu A; C_i = \text{Negligible}; L_i = \text{Negligible}$$

Connected Device Entity Parameters (will vary dependent upon device):

$U_i \text{ prog}$ = Max. voltage that can be connected at the input to the handheld or other programming device

$I_i \text{ prog}$ = Max. current that can be connected at the input to the handheld or other programming device

$P_i \text{ prog}$ = Max. power that can be connected at the input to the handheld or other programming device

$L_i \text{ prog}$ = Max. inductance that can be connected at the input to the handheld or other programming device

$C_i \text{ prog}$ = Max. capacitance that can be connected at the input to the handheld or other programming device

$U_o \text{ prog}$ = Max. voltage that the handheld or other programming device can source to the device being programmed

$I_o \text{ prog}$ = Max. current that the handheld or other programming device can source to the device being programmed

2.4.1 Download Device Description (DD)

We maintain registration and details, including latest DD, with FieldComm Group (www.fieldcommgroup.org). We have WirelessHART resources for the Vanguard at www.ueonline.com. The latest DD should also be available in updated libraries of major handheld programmers and DCS manufacturers.

2.4.2 Using a Handheld HART Communicator

- 1 If not previously done (from installing the battery – see Section 2.2 Battery Installation), unscrew the solid, back cover from the intrinsically safe battery compartment and set aside.
- 2 Confirm battery installation or install battery (see Section 2.2 Battery Installation).
- 3 Push the button on the side of the device to activate the wired HART interface.
- 4 Connect wires from handheld HART communicator to HART terminals (see Figure 15).
- 5 The handheld HART communicator will search for a HART-compatible device and indicate if a connection was made.
- 6 Obtain the Network ID and Join Key of the wireless network to which the device will be joined. This information can be found under the Settings section on the web server supporting the wireless Gateway. Consult the wireless Gateway manual for additional information.
- 7 Navigating through the handheld HART communicator menu, choose Configure Network ID and enter the Network ID. The operation will use WirelessHART commands 773-Write Network ID and 774-Read Network ID.
- 8 Navigating through the handheld HART communicator menu, choose Configure Join Key and enter the Join Key. This operation will use WirelessHART command 768-Write Join Key.
- 9 Upon inputting the Network ID and Join Key, the device initializes connection with the network in the following phases. The phase status will be indicated on the device display.

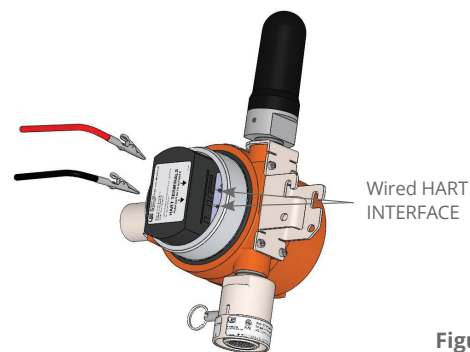

Figure 15

Searching: Once the device receives a join command, it proceeds to the Searching mode. The device keeps its receiver activated while searching for available networks (see Figure 16).

```
CH4: XXX % LEL
BATTERY: X.XX V
NET: SEARCHING
```

Figure 16

Negotiating: The device has detected the desired network and has received a join request from the network manager (see Figure 17).

```
CH4: XXX % LEL
BATTERY: X.XX V
NET: NEGOTIATING
```

Figure 17

Connected: The device should now be joined to the network (see Figure 18). If the device fails to join the wireless mesh network, consult the Troubleshooting Guide (see Section 5.0, page 16).

NOTE: Data transfer is not possible yet.

```
CH4: XXX % LEL
BATTERY: X.XX V
NET: CONNECTED
```

Figure 18

Operational: When the device has sufficient bandwidth with the network manager, data transfer can occur and the device is operational (see Figure 19).

```
CH4: XXX % LEL
BATTERY: X.XX V
NET: OPERATIONAL
```

Figure 19

- 10 Disconnect wires from the HART terminals and secure cover onto enclosure by tightening until all threads have been fully engaged to ensure proper ingress protection.

2.4.3 HART Modem

- 1 If not previously done (from installing the battery – see Section 2.2 Battery Installation), unscrew the solid, back cover from the intrinsically safe battery compartment and set aside.
- 2 Confirm battery installation or install battery (see Section 2.2 Battery Installation).
- 3 Push the button on the side of the device to activate the wired HART interface.
- 4 Connect wires from HART Modem to HART terminals (see Figure 15). **NOTE:** The HART modem should be connected to a computer running HART compatible software.
- 5 Obtain the Network ID and Join Key of the wireless network to which the device will be joined. This information can be found under the Settings section on the web server supporting the wireless Gateway. Consult the wireless Gateway manual for additional information.
- 6 There are two ways to connect to the wireless mesh network.
 - 1 Identify the device icon on the Gateway software and drag and drop the icon onto the Gateway icon.
 - 2 Open the device menu options and enter the Network ID and Join Key manually.
- 7 Upon inputting the Network ID and Join Key, the device initializes connection with the network in the following phases. The phase status will be indicated on the device display. Refer to Figures 16-19.
- 8 If the device fails to join the wireless mesh network, consult the Troubleshooting Guide (see Section 5.0, page 16).
- 9 Disconnect wires from the HART terminals and secure cover onto enclosure by tightening until all threads have been fully engaged to ensure proper ingress protection.

TO ENSURE PROPER INGRESS PROTECTION, THE REAR COVER MUST BE INSTALLED, AND FULLY BOTTOMED OUT AGAINST THE BASE ENCLOSURE (I.E., METAL-TO-METAL CONTACT). IT IS RECOMMENDED TO USE A WRENCH OR ANY TOOL ACROSS THE COVER LUGS TO TIGHTEN THE COVERS DOWN.

2.5 Sensor Placement Considerations

EXPOSURE TO TOXIC GAS MAY RESULT IN LOSS OF CONSCIOUSNESS OR DEATH. SEE ANNEX A FOR TOXIC GAS SENSOR DETAILS.

COMBUSTIBLE GAS ACCUMULATION IN CLOSED AREAS MAY CAUSE EXPLOSION, AND RESULT IN LOSS OF CONSCIOUSNESS OR DEATH. SEE ANNEX A FOR COMBUSTIBLE GAS SENSOR DETAILS.

THIS DEVICE MUST BE MOUNTED VERTICALLY WITH THE SENSOR POINTING DOWNWARD.

Individual applications need to be assessed for correct sensor placement. The target gas needs to be determined along with the gas density, and potential coverage area.

FOR GASES THAT ARE HEAVIER THAN AIR, SENSOR INSTALLATION IS RECOMMENDED NEAR THE GROUND AND BELOW THE POTENTIAL LEAK SOURCE.

FOR GASES THAT ARE LIGHTER THAN AIR, SENSOR INSTALLATION IS RECOMMENDED NEAR THE CEILING (IN AN ENCLOSED SPACE) AND ABOVE THE POTENTIAL LEAK SOURCE.

Chemical Abstracts Service (CAS), a division of the American Chemical Society, is the world's authority for chemical information. Please consult the database at www.cas.org for chemical properties of gas.

Other factors to consider include but are not limited to:

- **Location** – takes into account gas leak source, pressure of release, temperature, and distance to sensor.
- **Air flow** – prevailing winds, velocity, fans, exhaust ducts that could affect detection.
- **Environmental conditions** – other than air flow; such as exposure to water, snow, and dirt. Also temperature – hot and cold – and how that may affect the gas release.
- **Maintenance Accessibility** – provide safe access for calibration and maintenance.

2.6 Sensor Cross Sensitivity

Depending on the type of sensor installed, the device has the ability to detect either Toxic or Combustible gas. The tables and graph located in Annex A demonstrate the typical cross sensitivities of each sensor to other gases that may be present while monitoring.

2.7 Classified Area Installation

- DO NOT REMOVE THE FRONT (PAINTED ALUMINUM AND GLASS) COVER.**
- INSTALL DEVICE ONLY INTO AREAS MATCHING APPROVALS ON DEVICE LABELING.**
- INSTALL THE DEVICE WHERE SHOCK, VIBRATION AND TEMPERATURE FLUCTUATIONS ARE MINIMAL. DO NOT MOUNT IN AMBIENT TEMPERATURES THAT EXCEED THE LIMITS ON THE DEVICE LABELING.**
- TO PREVENT SEIZURE OF ENCLOSURE COVER, DO NOT REMOVE LUBRICANT. THREADS SHOULD ALSO BE FREE OF DIRT, ETC.**

2.8 Field Mounting

- THE MOUNTING BRACKET ATTACHMENT ON THIS DEVICE IS FACTORY-INSTALLED AND MUST NOT BE REMOVED AS IT MAY CAUSE PERMANENT DAMAGE TO THE ANTENNA, THE SENSOR ASSEMBLY, AND LOOSENING OF THE THREADED FLAME-PROOF JOINTS. REMOVAL WILL VOID HAZARDOUS LOCATION APPROVALS, AND MANUFACTURER WARRANTY.**
- THIS DEVICE MUST BE MOUNTED VERTICALLY WITH THE SENSOR POINTING DOWNWARD AND THE ANTENNA POINTING UPWARD.**

TO ENSURE PROPER INGRESS PROTECTION, THE REAR COVER MUST BE INSTALLED, AND FULLY BOTTOMED OUT AGAINST THE BASE ENCLOSURE (I.E., METAL-TO-METAL CONTACT). IT IS RECOMMENDED TO USE A WRENCH OR ANY TOOL ACROSS THE COVER LUGS TO TIGHTEN THE COVERS DOWN.

This device may be mounted in any of the following configurations using any of the three Vanguard FLEXmount™ options: Standard mount, Magnet mount, or Universal mount.

2.8.1 Standard Mount - Vertical

- 1 Remove hardware from packaging (see Figure 20).
- 2 Place one pipe mount adaptor [1] onto desired location horizontally on pipe and slide U-bolt [2] through holes.
- 3 Slide mounting bracket plate [3] onto U-bolt [2] and secure with (2x) hex nuts [4]. Do not tighten.
- 4 Repeat step 2 with second pipe mount adaptor [1] also sliding U-bolt [2] through mounting bracket plate [3] and securing with (2x) hex nuts [4].
- 5 Once position is set, tighten (4x) hex nuts using 1/2" wrench.

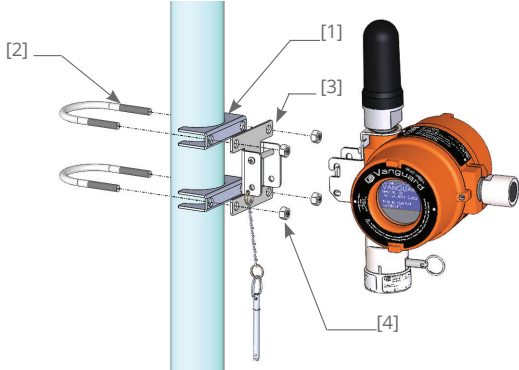

Figure 20

- 6 Mount device by hooking onto top pin of mounting bracket plate (see Figure 21).
- 7 Push attached pin [5] through bottom holes to secure device to the bracket (see Figure 22).



Figure 21



Figure 22

2.8.2 Standard Mount - Horizontal

IF EXPLOSIVE GASES ARE PRESENT, ENSURE THAT ANTI-STATIC TOOLS ARE USED.

- 1 Remove hardware from packaging (see Figure 23).
- 2 Place one pipe mount adaptor [1] onto desired location vertically on pipe and slide U-bolt [2] through holes.
- 3 Slide mounting bracket plate [3] onto U-bolt [2] and secure with (2x) hex nuts [4]. Do not tighten.
- 4 Repeat step 2 with second pipe mount adaptor [1] also sliding U-bolt [2] through mounting bracket plate [3] and securing with (2x) hex nuts [4].
- 5 Once position is set, tighten (4x) hex nuts using 1/2" wrench.
- 6 Mount device by hooking onto top pin of mounting bracket plate (see Figure 23).
- 7 Push attached pin [5] through bottom holes to secure device to the bracket (see Figure 24).

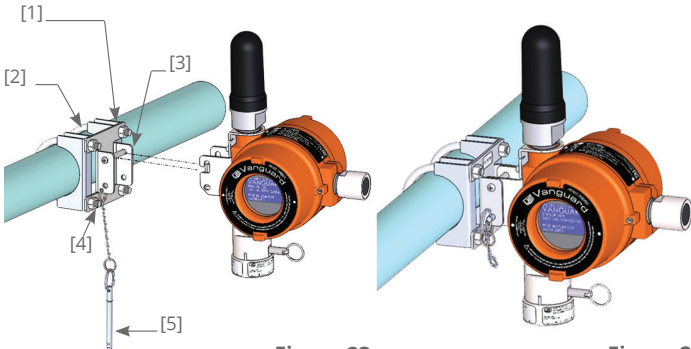

Figure 23

Figure 24

2.8.3 Standard Mount - Wall

WALL MOUNTING COULD AFFECT THE SIGNAL STRENGTH OF THE DEVICE.

IF EXPLOSIVE GASES ARE PRESENT, ENSURE THAT ANTI-STATIC TOOLS ARE USED.

- 1 Remove hardware from packaging (see Figure 25).
- 2 Hold mounting bracket plate [3] against wall/flat surface and screw tightly into place using (4x) mounting holes (0.40" dia.). **Note:** Mounting screws [6] not UE provided.
- 3 Mount device by hooking onto top pin of mounting bracket plate (see Figure 26).
- 4 Push attached pin [5] through bottom holes to secure device to the bracket (see Figure 27).

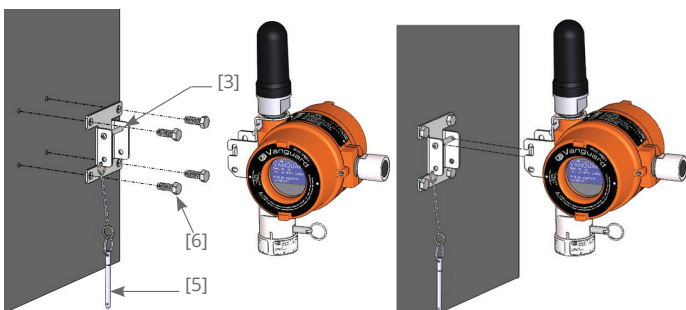

Figure 25

Figure 26



Figure 27

2.8.4 Magnetic Mount

CAUTION: MAGNETS MAY CAUSE PINCH POINTS.

MAGNET CONTACT FORCE IS DEPENDENT ON SURFACE CONDITION AND FLATNESS. MOUNT TO FLAT, DRY, CLEAN SURFACES THAT ARE NOT SUBJECT TO EXTREME ENVIRONMENTAL CONDITIONS.

THIS SOLUTION SHOULD NOT BE USED FOR OVERHEAD MOUNTING.

- 1 Remove hardware from packaging (see Figure 28).
- 2 Attach device to mounting bracket by hooking onto top pin of mounting bracket plate (see Figure 29).
- 3 Push attached pin [5] through bottom holes to secure device to the bracket (see Figure 30).
- 4 Align magnet mount [7] to mounting location.
- 5 Place onto location gently or using a top-to-bottom "peeling" motion (Figure 30).
- 6 Use the same top-to-bottom peeling motion to remove the mount from the wall.

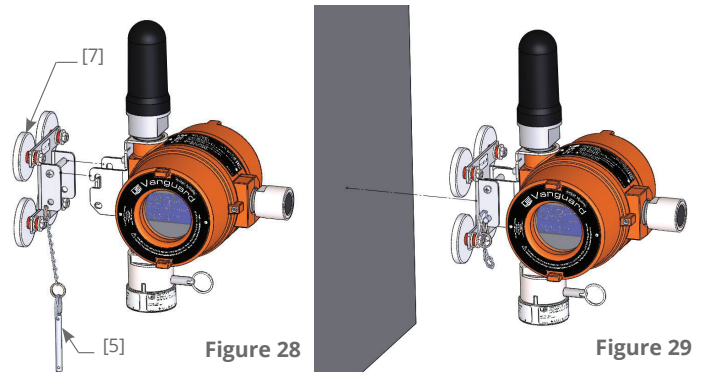

Figure 28

Figure 29

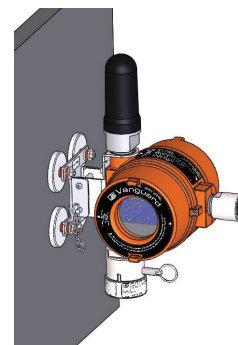

Figure 30

2.8.5 Universal Mount

IF EXPLOSIVE GASES ARE PRESENT, ENSURE THAT ANTI-STATIC TOOLS ARE USED.

- 1 Remove hardware from packaging (see Figure 31).
- 2 Feed straps [8] through bracket [3] using the bolt holes (see Figure 31).
- 3 Wrap steel straps around pipe or object to mount to and tighten using screw [9] (see Figure 32).
- 4 Mount device by hooking onto top pin of bracket plate (see Figure 33).
- 5 Secure with pin [5] by pushing through the bottom holes in the bracket (see Figure 34)

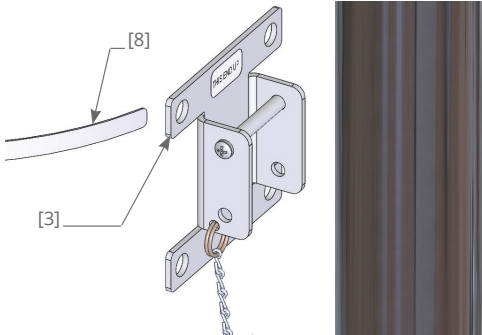

Figure 31

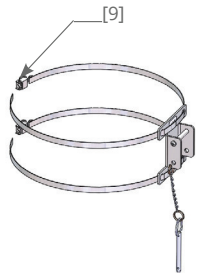

Figure 32

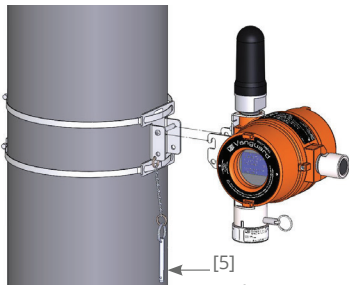

Figure 33

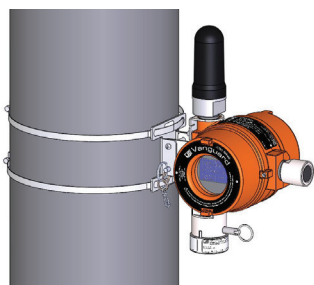

Figure 34

2.8.6 Device removal from mounting bracket plate

- 1 Pull attached pin [5] through bottom holes using the pull ring.
- 2 Pull device up and unhook from mounting bracket plate [3].

2.9 Optional Remote Mount Kit for Sensors

Users can place the sensor close to where gas can collect while position the Vanguard in a location more suitable for viewing during bump testing and calibrations. Examples include sensors installed in vaults, containers, or low to the ground.

THIS KIT WORKS WITH THE SAME SENSORS THAT ARE SHIPPED WITH THE VANGUARD TRANSMITTER. IT IS ALSO POSSIBLE TO RETROFIT EXISTING INSTALLATIONS WITH THE KIT.

The distance is limited to 9 feet (2.7 meters) due to the I.S. rating of the sensor and can only use UE kit (Part # 62169-70).

Included in the kit (Figure 35, shown with a TCD60):

- U-bolt (not shown)
- Remote sensor bracket and receiver [8]
- Armor Cable [9]
- Transmitter adapter [10]



Figure 35

2.10 Antenna Placement Considerations



THIS DEVICE COMPLIES WITH PART 15 OF THE FCC RULES: MAY NOT CAUSE HARMFUL INTERFERENCE; MUST ACCEPT ANY INTERFERENCE, INCLUDING THAT WHICH MAY CAUSE UNDESIRABLE OPERATION OF THE DEVICE.



TO COMPLY WITH IC RF EXPOSURE COMPLIANCE REQUIREMENTS, THE ANTENNA USED FOR THIS DEVICE MUST BE INSTALLED TO PROVIDE A SEPARATION DISTANCE OF AT LEAST 20 CM FROM ALL PERSONS.



FCC ID SJC-ETERNA2 CONTAINS IC 5853(A)-ETERNA2 CE0976



WALL MOUNTING COULD AFFECT THE SIGNAL STRENGTH OF THE DEVICE.

The antenna supplied with the device is an omnidirectional antenna, affixed to the product. In order to facilitate communication with other WirelessHART devices as part of a wireless mesh network, it is recommended that the device be mounted with minimum obstructions and noise interference. The maximum range of communication between the device and other devices (instrumentation, repeaters, gateways) is 750 feet (229 meters).

3.0 OPERATION



MISUSE OF THIS PRODUCT MAY CAUSE EXPLOSION AND/OR PERSONAL INJURY. THESE INSTRUCTIONS MUST BE THOROUGHLY READ AND UNDERSTOOD PRIOR TO INSTALLATION OF THE UNIT.



THE END-USER IS RESPONSIBLE FOR MAINTAINING THE DEVICE IN FULL, OPERATIONAL CONDITION.

3.1 Normal Operation

Under normal operation, the four variables (Table 1) are communicated via WirelessHART 7.9 communication protocol every 8 seconds by default using burst message 0. The update rate is programmable from 8 seconds up to 3600 seconds. Up to three burst messages (0-2) can be configured using the device descriptor. The burst message transmits a chosen HART command to publish data. HART commands that can be burst include: 1, 2, 3, 9, 33, and 48. The default configuration uses command 9 and 48.

NOTE: At the device, via the local, digital display, two variables are communicated by pushing the button once – the PV and QV (see Table 1).

Device Variable	Process Variable	Units	Accessibility
Primary Variable (PV)	Gas Concentration	ppm, %LEL	Read
Secondary Variable (SV)*	Temperature	Degrees C	Read
Tertiary Variable (TV)	Days Since Calibration	Days	Read
Quaternary Variable (QV)	Battery Voltage	Volts	Read

* Not available on all combustible sensors.

Table 1

The following procedure should be used to configure a burst message:

- 1 Turn off any burst messages to be changed prior to configuration.
- 2 Select the burst message and HART command for publishing. Consider what update rate is to be used based on application. Faster update rates can impact battery life.
- 3 Enable burst messages.

3.2 Sensor Calibration & Bump Test



THOROUGHLY READ AND UNDERSTAND ALL SAFETY DATA SHEETS (SDS) AND WARNINGS ASSOCIATED WITH GASES USED FOR CALIBRATION AND/OR BUMP TESTING.



DURING SENSOR CALIBRATION MODE, THE DEVICE IS OPERATIONAL BUT NOT COMMUNICATING DATA. PROPER CARE SHOULD BE TAKEN TO ENSURE THAT SURROUNDING ENVIRONMENT IS FREE OF TOXIC OR COMBUSTIBLE GASES. IT IS RECOMMENDED THAT OTHER GAS DETECTION BE DEPLOYED DURING SENSOR CALIBRATION AND/OR BUMP TESTING TO PREVENT EXPLOSION, SERIOUS INJURY OR DEATH.



SENSORS MUST BE ACTIVATED BEFORE USE (SEE 2.3 SENSOR ACTIVATION, PAGE 5)

Depending upon the use of the device, a calibration check or a bump test may need to be performed. It is recommended to perform the calibration or bump test with the UE Vanguard gas calibration kit (setup instructions included) with a flow rate of approximately 0.5 LPM for best results. Either of these tests are done to ensure that the sensor will respond as intended to a predetermined, measured gas release. UE recommends following the end user's standard practices for gas detection sensor calibration and bump testing. See Annex A for sensor detection ranges. Measured values within the measuring range of the sensor are indicated on the display as well as communicated using WirelessHART. Values below zero (negative) may be indicated as zero but with a status bit that conveys reading has drifted negative. Reference Annex A for additional details.

3.2.1 Bump Test

- 1 Select and use a test gas cylinder of a known concentration. **NOTE:** Combustible LEL sensors are maintenance-free and do not require calibration for up to 6 months. However, UE does recommend periodic bump testing to assure optimum performance. Sensors may require more frequent calibration when exposed to moisture, excessive temperatures or humidity.
- 2 If the reading on the display does not match the analytical composition of the test gas cylinder go to section 3.2.2 to calibrate the Vanguard.

3.2.2 Sensor Calibration

- 1 Select and use a test gas cylinder of a known concentration of the sensor being calibrated. The concentration of the test gas must be between 10% to 100% of the full scale range of the sensor. **NOTE:** See Annex A for factory settings of expected test gas concentration. This configuration for test gas concentration can be changed using HART command 129.
- 2 Press and hold the calibration button for 10 seconds to begin the calibration process. **NOTE:** During this process, the device will be placed in calibration mode. The primary variable (i.e., gas concentration) will still be transmitted to the gateway but fixed at a value of 0. A mode bit indicating that the device is in calibration mode will also be transmitted. This feature is to avoid false alarms during calibration.



IF THERE IS NO ACTIVITY DETECTED FOR 10 MINUTES DURING THE CALIBRATION MODE, THE DEVICE WILL RETURN TO MEASUREMENT MODE.

3 OFFSET ZEROING

The screen shown in Figure 36 will appear. Apply dry air or nitrogen to the sensor port. Wait 2 minutes for the sensor to adjust. Press and hold the calibration button for 10 seconds. Offset zeroing will show the prompt, in Figure 37 for up to 1 minute.

CH₄: XXX % LEL
PRESS AND HOLD BUTTON
TO ZERO SENSOR
OR PUSH TO ABORT

Figure 36

ZEROING

Figure 37

4 SPAN ADJUSTMENT

If a successful offset calibration was performed, the prompt shown in Figure 38 will be displayed. If calibration was unsuccessful, the prompt shown in Figure 39 will be displayed. Please try re-zeroing the sensor or contact UE Technical Sales Support.

CH₄ : XX
APPLY XX %LEL CAL GAS
AND HOLD TO CALIBRATE
OR PUSH TO ABORT %LEL

Figure 38

FAILED
RECALIBRATE OR
REPLACE SENSOR

Figure 39

5 Apply the test gas to the sensor with the aid of the UE Vanguard gas calibration kit.

6 Apply the gas for a minimum of 2 minutes or until gas concentration readings on the display are stable. (See Annex A for details.)

7 Push and hold the button for approximately 10 seconds. The display will change to Figure 40, and remain for up to 1 minute.

CALIBRATING
PLEASE
WAIT

Figure 40

8 Successful calibration will display "Calibration Done" on the local display (See Figure 41)

CALIBRATION
DONE
SET TO: XX %LEL

Figure 41

UNSUCCESSFUL CALIBRATION WILL DISPLAY 'CALIBRATION FAILED' ON THE LOCAL, DIGITAL DISPLAY. THIS INDICATES THAT THE SENSOR READING IS OUT OF SPECIFICATION AND A NEW SENSOR IS REQUIRED (SEE SECTION 4.1 SENSOR REPLACEMENT).

9 Remove calibration cup and allow gas to clear, as shown in Figure 42. **NOTE:** Device will return to measurement mode when concentration is less than 2% of full scale range.

CH₄: XX
REMOVE AND CLEAR GAS
THEN PUSH TO RETURN %LEL

Figure 42

3.2.3 Sensor time Response Measurement

1 Zero and span the sensor using the procedure in 3.2.2.

2 Apply dry nitrogen or air to the sensor port and wait 2 minutes for the zero value to stabilize.

3 Apply calibration gas using cal kit and begin timer. Timer should be set to the response time specified in annex for the sensor in use.

4 When the timer expires, read the gas concentration from the unit. It should be within 10% of the cal gas, if it is not, the sensor is not functioning properly and should be returned.

3.3 Programming mode

This section describes the HART Commands used in the device.

3.3.1 Universal Commands

The Universal Commands are the minimum command set for all HART devices and provide access to information useful in normal device operation.

Table 2 shows the supported Universal Commands for this device.

0	Read Unique Identifier
1	Read Primary Variable
2	Read Loop Current and Percent Range
3	Read Dynamic Variables and Loop Current
6	Write Polling Address
7	Read Loop Configuration
8	Read Dynamic Variable Classifications
9	Read Device Variables with Status
11	Read Unique Identifier Associated with Tag
12	Read Message
13	Read Tag, Descriptor, Date
14	Read Primary Variable Transducer Information
15	Read Device Information
16	Read Final Assembly Number
17	Write Tag, Descriptor, Date
18	Write Tag, Descriptor, Date
19	Write Final Assembly Number
20	Read Long Tag
21	Read Unique Identifier Associated with Long Tag
22	Write Long Tag
38	Reset Configuration Changed Flag
48	Read Additional Device Status

Table 2

3.3.2 Common Practice Commands

The Common Practice Commands are an optional command set for HART devices. Table 3 shows the supported Common Practice Commands for this device.

33	Read Unique Identifier
34	Read Primary Variable
35	Read Loop Current and Percent Range
42	Read Dynamic Variables and Loop Current
44	Write Polling Address
47	Read Loop Configuration
50	Read Dynamic Variable Classifications
51	Read Device Variables with Status
54	Read Unique Identifier Associated with Tag
59	Read Message
78	Read Tag, Descriptor, Date
79	Read Primary Variable Transducer Information
90	Read Real-Time Clock
103	Write Burst Period
104	Write Burst Trigger
105	Read Burst Mode Configuration
106	Flush Delayed Response Buffers
107	Write Burst Device Variables
108	Write Burst Mode Command Number
109	Burst Mode Control
115	Read Event Notification Bit Mask
116	Write Event Notification Bit Mark

117	Write Event Notification Timing
118	Event Notification Control
119	Acknowledge Event Notification

Table 3

3.3.3 Device Specific Commands

The Device Specific Commands are commands unique to this device only. These commands are included in the Device Description (DD). Download the latest DD* at www.ueonline.com or www.fieldcommgroup.org to ensure optimum communication between HART devices, gateway and host system. Table 4 shows the supported Device Specific Commands for this device.

* The downloaded files should be placed in a folder named with the manufacturer ID number and then a child folder created using the device type number. The folder should then be copied to the directory where DD files are stored. New DD files simply replace the old and work with all revisions of the same device.

128	Read Calibration Point
129	Write Calibration Point
131	Read Sensor Activation State
132	Read Base Unit Configuration String
133	Read Sensor Module Configuration String
138	Read Sensor Type String
548	Read Lock Status
549	Attach Lock
550	Unlock

Table 4

3.3.4 HART Command 128 Read Calibration Point

Request bytes:		
Bytes	Format	Description
None		

Response bytes:		
Bytes	Format	Description
0-3	Float	Concentration of gas used during calibration

Command Specific Response Code:		
Bytes	Format	Description
0	Success	No command specific errors

Table 5

3.3.5 HART Command 129 Write Calibration Point

Request bytes:		
Bytes	Format	Description
0-3	Float	Concentration of gas used during calibration

Response bytes:		
Bytes	Format	Description
0-3	Float	Concentration of gas used during calibration

Command Specific Response Code:		
Code	Class	Description
0	Success	No command specific errors
2	Error	Concentration too low
3	Error	Concentration too high
4	Error	Concentration not valid
5	Error	Incorrect number of data bytes received

Table 6

3.3.6 HART Command 131 Read Sensor Activation State

Request bytes:		
Bytes	Format	Description
None		

Response bytes:		
Bytes	Format	Description
0-1	Unsigned-16	Sensor type (0=Not Activated)

Command Specific Response Code:		
Code	Class	Description
0	Success	No command specific errors

Table 7

3.3.7 HART Command 132 Read Base Unit Configuration String

Request bytes:		
Bytes	Format	Description
None		

Response bytes:		
Bytes	Format	Description
0-39	Latin-1	Unit Configuration String, (e.g., UEC100 SW 2.20 HW 1.21)

Command Specific Response Code:		
Code	Class	Description
0	Success	No command specific errors

Table 8

3.3.8 HART Command 133 Read Sensor Module Configuration String

Request bytes:		
Bytes	Format	Description
None		

Response bytes:		
Bytes	Format	Description
0-39	Latin-1	Sensor Module Configuration String (e.g., H2S: 02031 08035278 02 MIPEX-2_25.6)

Command Specific Response Code:		
Code	Class	Description
0	Success	No command specific errors

Table 9

3.3.9 HART Command 138 Read Sensor Type String

Request bytes:		
Bytes	Format	Description
0	Unsigned 8	Device Variable Code

Response bytes:		
Bytes	Format	Description
0	Unsigned 8	Device Variable Code
1-16	ISO-Latin1	Variable Type String

Command Specific Response Code:		
Code	Class	Description
0	Success	No command specific errors
1	Error	Wrong Number of Data Bytes
2	Error	Invalid Selection

Table 10

3.3.10 HART Command 548 Read Sensor Lock Status

Request bytes:		
Bytes	Format	Description
None		

Response bytes:		
Bytes	Format	Description
0	Unsigned 8	Cut Lock Authorization (Common Table 85)
1	Unsigned 8	Lock Status (Common Table 83)
2	Unsigned 8	Number of Locks
3-26	ISO-Latin1	Username 1
27-50	ISO-Latin1	Username 2

Command Specific Response Code:		
Code	Class	Description
0	Success	No command specific errors

Table 11

3.3.11 HART Command 549 Attach Write Protect Lock

Request bytes:		
Bytes	Format	Description
0	Unsigned 8	Write protect status (0x02)
1		Reserved
2-25	ISO-Latin1	Username
26-49	ISO-Latin1	Password

Response bytes:		
Bytes	Format	Description
0	Unsigned 8	Write protect status
1	Unsigned 8	Number of Locks
2-25	ISO-Latin1	Username
26-49	ISO-Latin1	Password

Command Specific Response Code:		
Code	Class	Description
0	Success	No command specific errors
2	Fail	Invalid selection
5	Fail	Too few bytes received
10	Fail	No locks available
11	Fail	Invalid user
12	Fail	Duplicate user
13	Fail	Invalid combination (not long enough)

Table 12

3.3.12 HART Command 550 Remove Write Protect Lock

Request bytes:		
Bytes	Format	Description
0		Reserved
1		Reserved
2-25	ISO-Latin1	Username
26-49	ISO-Latin1	Password

Response bytes:		
Bytes	Format	Description
0	Unsigned 8	Write protect status
1	Unsigned 8	Number of Locks
2-25	ISO-Latin1	Username
26-49	ISO-Latin1	Password

Command Specific Response Code:		
Code	Class	Description
0	Success	No command specific errors
5	Fail	Too few bytes received

Table 13

4.0 FIELD REPLACEMENT

4.1 Sensor Replacement

! THE SENSOR IS CERTIFIED INTRINSICALLY SAFE. SENSOR REPLACEMENT MAY BE PERFORMED IN THE FIELD WITHOUT A HOT WORK PERMIT.

! ONLY FLEXSENSE™ SENSORS PROVIDED BY UNITED ELECTRIC CONTROLS ARE COMPATIBLE WITH THIS DEVICE.

! DO NOT ATTEMPT TO DISASSEMBLE THE SENSOR AS THIS COULD DAMAGE THE SENSOR AND VOID HAZARDOUS LOCATION APPROVALS, AND MANUFACTURER WARRANTY.

! WHEN REPLACING THE SENSOR, PROPER CARE SHOULD BE TAKEN TO ENSURE THAT SURROUNDING ENVIRONMENT IS FREE OF TOXIC OR COMBUSTIBLE GASES. IT IS RECOMMENDED THAT OTHER GAS DETECTION BE DEPLOYED DURING SENSOR REPLACEMENT TO PREVENT EXPLOSION, SERIOUS INJURY OR DEATH.

i SENSORS MUST BE ACTIVATED AFTER INSTALLATION (SEE 2.3 SENSOR ACTIVATION, PAGE 5).

Locate the FLEXsense™ sensor housing (see Figure 43) and retract the sensor locking pin, twisting 90 degrees to lock into retracted position. Remove the gas sensor assembly by firmly pulling downward and releasing it from the sensor unit (see Figure 44). Remove the new FLEXsense™ sensor from its package and follow the instructions from Section 2.1 Sensor Installation.

NOTE: It is not necessary to remove the battery during sensor replacement.

i UE RECOMMENDS PERFORMING THE SENSOR CALIBRATION PROCEDURE AS OUTLINED IN SECTION 3.2 SENSOR CALIBRATION & BUMP TEST (SEE PAGE 11).

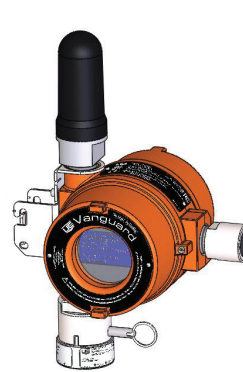

Figure 43



Figure 44

4.2 Battery Replacement

! THE BATTERY COMPARTMENT IS CERTIFIED INTRINSICALLY SAFE. BATTERY REPLACEMENT MAY BE PERFORMED IN THE FIELD WITHOUT A HOT WORK PERMIT.

- ⚠ ONLY BATTERY PACKS PROVIDED BY UNITED ELECTRIC CONTROLS ARE COMPATIBLE WITH THIS DEVICE.**

- ⚠ WHEN REPLACING THE BATTERY, PROPER CARE SHOULD BE TAKEN TO ENSURE THAT SURROUNDING ENVIRONMENT IS FREE OF TOXIC OR COMBUSTIBLE GASES. IT IS RECOMMENDED THAT OTHER GAS DETECTION BE DEPLOYED DURING BATTERY REPLACEMENT TO PREVENT EXPLOSION, SERIOUS INJURY OR DEATH.**

- ⚠ FOLLOW PROPER DISPOSAL REGULATIONS FOR LITHIUM BATTERIES AS APPLIES TO THE LOCAL JURISDICTION.**

- i BATTERIES ARE NOT RECHARGEABLE.**

- i THE SENSOR MUST BE CALIBRATED AFTER BATTERY REPLACEMENT (SEE SECTION 3.2).**

Slide the battery pack out of the compartment (see Figure 46). Remove the new battery from its packaging and follow steps 3-6, from Section 2.2 Battery Installation.

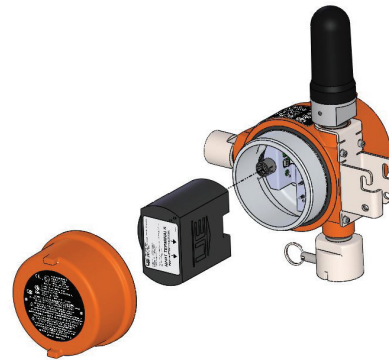

Figure 46

i TO ENSURE PROPER INGRESS PROTECTION, THE REAR COVER MUST BE INSTALLED, AND FULLY BOTTOMED OUT AGAINST THE BASE ENCLOSURE (I.E., METAL-TO-METAL CONTACT). IT IS RECOMMENDED TO USE A WRENCH OR ANY TOOL ACROSS THE COVER LUGS TO TIGHTEN THE COVERS DOWN.

Locate the battery compartment and remove the battery compartment cover to expose the battery. Remove the battery by gripping the back of the battery pack and firmly pulling back from the enclosure, releasing it from the battery socket.

5.0 TROUBLESHOOTING GUIDE

The Vanguard WirelessHART gas detector is used as part of a wireless mesh network that may communicate with other manufacturers' WirelessHART devices, Gateways, and control systems. The following provides troubleshooting suggestions for common operating problems that may be encountered.

5.1 Hardware

SYMPTOM	POSSIBLE CAUSES	RECOMMENDED ACTION
Sensor is not recognized by the device	Poor connection between sensor and device	Check the integrity of the 8-pin connector in the sensor. Pins must not be bent.
	Incorrect placement of sensor	Ensure that the sensor is completely snapped in place.
Device does not operate (i.e., device does not refresh even if button was pushed)	Battery not connected properly	Check the battery is seated properly in the battery compartment. Check the integrity of the 5-pin connector at the battery port. Pins must not be bent.
	Battery is dead	Replace battery.
Device unable to move beyond the idle or search mode	Incorrect Network ID and Join Key	Check the Network ID and Join Key and attempt rejoining network.
	Network is not self advertising	Check that the network is in the active network advertise mode. Power cycle device and try again.
Device is not responding to the calibration gas	Incorrect gas or gas concentration	Check gas type and concentration.
	Incorrect calibration	Review the Calibration procedure listed within on page 11.
	Poor gas delivery	Check gas delivery equipment components.
	Poor connection between sensor and device	Check the integrity of the 8-pin connector in the sensor. Ensure that the sensor is completely snapped into place. Replace the sensor.
LCD does not refresh	Extreme ambient temperature	Transfer device within temperature range -40°C (-40°F) to 65°C (149°F).
	Battery is dead	Replace battery.
LCD has slow refresh rate	Battery not connected properly	Check the battery is seated properly in the battery compartment. Check the integrity of the 5-pin connector at the battery port.
	Extreme ambient temperature	A slow refresh rate is normal at low temperature. This is intentional to enhance the viewing of the LCD.
Device freezes, does not send data, LCD does not refresh	Critical safety error has occurred (memory or power issue)	Remove and replace battery, device should boot normally. An error code should replace the device long tag, which can be seen on the screen. Note the error and change the tag back. If the error occurs again in the next 24 hours, the device must be returned to the factory.

Table 14

5.2 Wireless Communication

Upon inputting the Network ID and Join Key, the device initializes connection with the network in the following phases. The phase status will be indicated on the device display.

1. **IDLE:** The device is accepting configuration commands. Once it receives a join command, it proceeds to the Searching mode.
2. **SEARCHING:** The device keeps its receiver activated while searching for available networks.
3. **NEGOTIATING:** The device has detected the desired network and has received a join request from the network manager.
4. **CONNECTED:** The device has established connection with the network manager and has successfully joined the network. Data transfer is not possible yet.
5. **OPERATIONAL:** The device has sufficient bandwidth for communication with the network manager. Data transfer can now occur.

NOTE: If a handheld communicator is unavailable, use the following WirelessHART Commands to initialize the join process:

- 768 - Write Join Key
- 773 - Write Network ID
- 774 - Read Network ID

Possible issues during the connection process are highlighted in Table 15 below:

SYMPTOM	POSSIBLE CAUSES	RECOMMENDED ACTION
Device is not joining the network	Battery is not connected properly	Check that the battery is connected correctly. See Section 2.1 on battery installation.
	Incorrect Network ID and Join Key	Check the Network ID and Join Key
	Network is not self advertising	Check that the network is in the active network advertise mode
	Insufficient routing nodes	Check that the device is within the range of at least one other device in the mesh network. Add more wireless points
	Network is oversubscribed with devices	Check that the maximum devices on the network has not been exceeded Wait for at least 15 minutes after the start up Power cycle device and try again
Excessive network rejoins	Antenna issue	Send the device back to factory
		Check antenna signal strength on asset management system
	Unreliable routing nodes	Relocate device so it has multiple communication paths or add another node in between

Table 15

6.0 DIMENSIONAL DRAWINGS

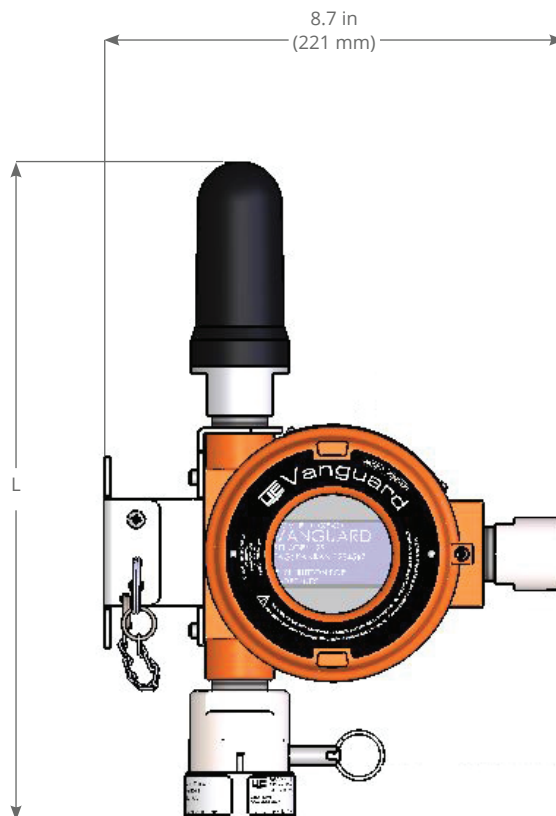
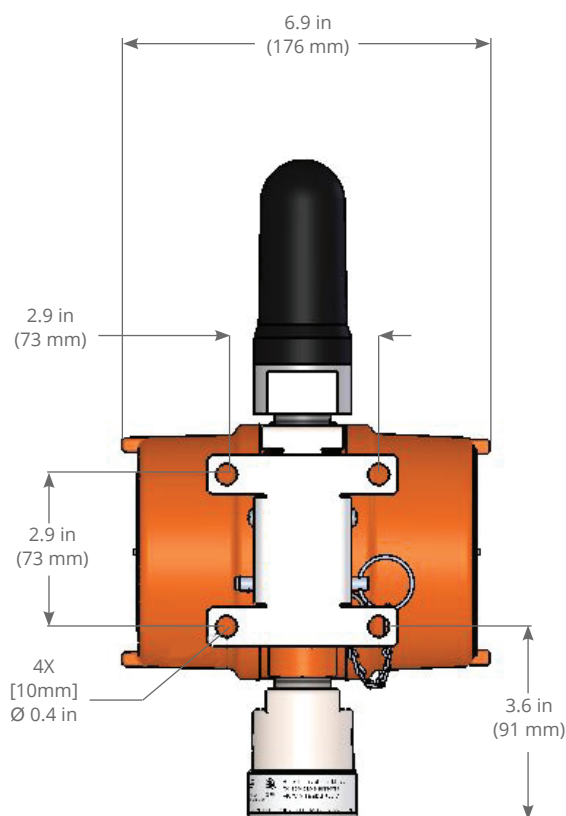

TCD50 shown with Standard Mount

Models	Antenna	Gain (dBi)	L
TCD50	1	2	12.4" (315 mm)

7.0 NAMEPLATES

7.1 Front Cover Nameplate



1. WARNING: DO NOT OPEN WHEN EXPLOSIVE ATMOSPHERE IS PRESENT. KEEP COVER TIGHT WHILE IN OPERATION
 1. AVERTISSEMENT : NE PAS OUVRIR EN PRÉSENCE D'UNE ATMOSPHÈRE EXPLOSIVE. GARDER LE COUVERCLE FERMÉ PENDANT LE FONCTIONNEMENT



2. WARNING - POTENTIAL ELECTROSTATIC CHARGING HAZARD - SEE INSTRUCTIONS
 2. AVERTISSEMENT - DANGER POTENTIEL DE CHARGE ÉLECTROSTATIQUE - VOIR INSTRUCTIONS

7.2 Back Cover Nameplate



3. WARNING: REFERENCE INSTALLATION MANUAL FOR GUIDANCE ON COMPATIBILITY OF INTRINSICALLY SAFE HART DEVICES.
 3. AVERTISSEMENT: CONSULTER LE MANUEL D'INSTALLATION POUR OBTENIR DES CONSEILS SUR LA COMPATIBILITÉ DES DISPOSITIFS HART À SÉCURITÉ INTRINSÈQUE.



4. WARNING: TO PREVENT IGNITION, USE ONLY SENSORS AND BATTERIES SUPPLIED BY UNITED ELECTRIC CONTROLS. USE UE BATTERY (VMAX = 7.8V, IMAX = 0.17A) ASSY # 6361-807.
 4. AVERTISSEMENT: POUR ÉVITER TOUTE INFLAMMATION, N'UTILISEZ QUE DES CAPTEURS ET DES BATTERIES FOURNIS PAR UNITED ELECTRIC CONTROLS. UTILISEZ LES BATTERIES UE (VMAX = 7,8V, IMAX = 0,17A) ASSY # 6361-807.

8.0 WARNING FRENCH TRANSLATIONS

Pg	WARNING TEXT	TEXTE D'AVERTISSEMENT
1	ALL WARNINGS MUST BE THOROUGHLY READ, UNDERSTOOD AND FOLLOWED.	Ces consignes doivent être lues attentivement et bien comprises avant l'installation de l'appareil.
1	MISUSE OF THIS DEVICE AND FAILURE TO ADHERE TO ALL WARNINGS COULD RESULT IN: • THE DEVICE NOT PERFORMING AS INTENDED, • RISK OF EXPLOSION, • RISK OF LOSING CONSCIOUSNESS OR DEATH.	Une mauvaise utilisation de cet appareil et le non-respect des consignes de sécurité peuvent provoquer: - un mauvais fonctionnement de l'appareil, - un risque d'explosion, - des risques de perte de conscience ou la mort
2	MISUSE OF THIS DEVICE MAY CAUSE EXPLOSION AND/OR PERSONAL INJURY. THESE INSTRUCTIONS MUST BE THOROUGHLY READ AND UNDERSTOOD PRIOR TO INSTALLATION OF THE DEVICE.	Une mauvaise utilisation de cet appareil peut provoquer une explosion et/ou des blessures. Ces consignes doivent être lues attentivement et bien comprises avant l'installation de l'appareil.
4	TO PREVENT IGNITION, USE ONLY BATTERY PACKS SUPPLIED BY UNITED ELECTRIC CONTROLS .	Pour éviter toute inflammation, n'utilisez que des batteries fournis par United Electric Controls.
4	TO PREVENT IGNITION, ONLY USE SENSORS PROVIDED BY UNITED ELECTRIC CONTROLS .	Pour éviter toute inflammation, n'utilisez que des capteurs fournis par United Electric Controls.
8	DO NOT REMOVE THE FRONT (PAINTED ALUMINUM AND GLASS) COVER WHEN EXPLOSIVE ATMOSPHERE IS PRESENT.	Ne pas retirer la face avant de l'appareil (en verre et aluminium peint) en zone dangereuse.
10	THIS DEVICE COMPLIES WITH PART 15 OF THE FCC RULES: MAY NOT CAUSE HARMFUL INTERFERENCE; MUST ACCEPT ANY INTERFERENCE, INCLUDING THAT WHICH MAY CAUSE UNDESIRE OPERATION OF THE DEVICE.	Cet appareil est conforme à la Section 15 du règlement FCC : ne doit pas provoquer d'interférences nuisibles ; doit accepter n'importe quelle interférence, y compris celles qui pourraient provoquer un dysfonctionnement de l'appareil.
10	TO COMPLY WITH IC RF EXPOSURE COMPLIANCE REQUIREMENTS, THE ANTENNA USED FOR THIS DEVICE MUST BE INSTALLED TO PROVIDE A SEPARATION DISTANCE OF AT LEAST 20 CM FROM ALL PERSONS.	Afin de se conformer aux normes d'exposition RF d'Industrie Canada, l'antenne utilisée pour cet appareil doit être installée de façon à avoir une distance de séparation d'au moins 20 cm de toutes les personnes à proximité.
10	FCC ID SJC-ETERNA2 CONTAINS IC 5853(A)-ETERNA2 CE0976	16 FCC ID SJC-ETERNA2 contains IC 5853(A)-ETERNA2 CE0976 FCC ID SJC-ETERNA2 contient IC 5853(A)-ETERNA2 CE0976
15	THE SENSOR IS CERTIFIED INTRINSICALLY SAFE. SENSOR REPLACEMENT MAY BE PERFORMED IN THE FIELD WITHOUT A HOT WORK PERMIT.	Le capteur est certifié à sécurité intrinsèque. Le remplacement du capteur peut être effectué sur le terrain sans permis de travail à chaud.
15	ONLY FLEXSENSE™ SENSORS PROVIDED BY UNITED ELECTRIC CONTROLS ARE COMPATIBLE WITH THIS DEVICE.	Seuls les capteurs FLEXsense™ fournis par United Electric Controls sont compatibles avec cet appareil.
15	DO NOT ATTEMPT TO DISASSEMBLE THE SENSOR AS THIS COULD DAMAGE THE SENSOR AND VOID HAZARDOUS LOCATION APPROVALS, AND MANUFACTURER WARRANTY.	Ne pas tenter de démonter le capteur. Ceci pourrait l'endommager et annuler les autorisations d'utilisation dans des endroits dangereux ainsi que la garantie de fabricant.
15	WHEN REPLACING THE SENSOR, PROPER CARE SHOULD BE TAKEN TO ENSURE THAT SURROUNDING ENVIRONMENT IS FREE OF TOXIC OR COMBUSTIBLE GASES. IT IS RECOMMENDED THAT OTHER GAS DETECTION BE DEPLOYED DURING SENSOR REPLACEMENT TO PREVENT EXPLOSION, SERIOUS INJURY OR DEATH.	Il est important de s'assurer que l'environnement ne contient aucun gaz toxique ou combustible lors du remplacement du capteur. Il est recommandé d'utiliser un autre système de détection de gaz pendant le remplacement du capteur pour éviter tout risque d'explosion, de blessures graves ou de mort.
15	THE BATTERY COMPARTMENT IS CERTIFIED INTRINSICALLY SAFE. BATTERY REPLACEMENT MAY BE PERFORMED IN THE FIELD WITHOUT A HOT WORK PERMIT.	Le compartiment pour la batterie est certifié à sécurité intrinsèque. Le remplacement de la batterie peut être effectué sur le terrain sans permis de travail à chaud.
16	ONLY BATTERY PACKS PROVIDED BY UNITED ELECTRIC CONTROLS ARE COMPATIBLE WITH THIS DEVICE.	Seuls les packs de batteries fournis par United Electric Controls sont compatibles avec cet appareil.
16	WHEN REPLACING THE BATTERY, PROPER CARE SHOULD BE TAKEN TO ENSURE THAT SURROUNDING ENVIRONMENT IS FREE OF TOXIC OR COMBUSTIBLE GASES. IT IS RECOMMENDED THAT OTHER GAS DETECTION BE DEPLOYED DURING BATTERY REPLACEMENT TO PREVENT EXPLOSION, SERIOUS INJURY OR DEATH.	Il est important de s'assurer que l'environnement ne contient aucun gaz toxique ou combustible lors du remplacement de la batterie. Il est recommandé d'utiliser un autre système de détection de gaz pendant le remplacement de la batterie pour éviter tout risque d'explosion, de blessures graves ou de mort.
16	FOLLOW PROPER DISPOSAL REGULATIONS FOR LITHIUM BATTERIES AS APPLIES TO THE LOCAL JURISDICTION.	Suivre les règles d'élimination appropriées pour les piles au lithium à la juridiction locale.



United Electric Controls is ISO 9001:2015 certified
WirelessHART® is a registered trademark of FieldComm Group.
FLEXsense™ and FLEXmount™ are trademarks of United Electric Controls Co.

TERMS AND CONDITIONS OF SALE



UE specifications subject to change without notice.



180 Dexter Avenue
Watertown, MA 02472 - USA
Telephone: 617 926-1000 - Fax: 617 926-2568
www.ueonline.com

FOR A LIST OF OUR INTERNATIONAL AND
DOMESTIC REGIONAL SALES OFFICES
PLEASE VISIT OUR WEBPAGE
WWW.UEONLINE.COM