



The Sensor Box™

Instructions for assembling
an industrial temperature sensor

Installation and Operation Instructions

Please read all instructional literature carefully and thoroughly before starting.
Refer to the final page for the Warranty.

GENERAL

For:

- Spring Loaded Assemblies - Go To Part 1
- Sheath with Leadwire Assemblies - Go To Part 2

Part I - Assemble the Process Connection Hardware to the Terminal Head



TOOLS NEEDED:

- Pipe wrench
- Tape measure

COMPONENTS NEEDED:

- Connection hardware
- Terminal head

Depending on your installation, you may have to assemble a Nipple (N), Nipple-Union (NU) or Nipple-Union-Nipple (NUN) to your terminal head (See Figure 1).

- 1 Using a pipe wrench, firmly tighten the components to the head. **Note:** The stamping on the union should face the head.
- 2 Measure the resulting distance from the bottom face of the head to the bottom of the connection hardware, minus 0.5" - this will be used in determining the sensor housing dimension (Part 2).



FOR BEST RESULTS, USE LOCKTITE OR SIMILAR THREAD-SEALER ON ALL CONNECTIONS

Note: The standard EK1000 kit standardly contains 2" carbon steel nipples and unions, allowing you to assemble connections as follows:

- N = 1"
- NU = 3"
- NUN = 4"

For additional flexibility, you may order different length nipples. The chart below illustrates the most common options, along with their dimensions:

Nipple Part Numbers				
Carbon steel*	Nipple length	"N" Dimension	"NU" Dimension	"NUN" Dimension
NC1001	1"	0	2"	2 1/2"
NC1002	2"	1"	3"	4"
NC1003	3"	2"	4"	6"
NC1004	4"	3"	5"	8"
NC1006	6"	5"	7"	12"

* For stainless steel, change NC to NS

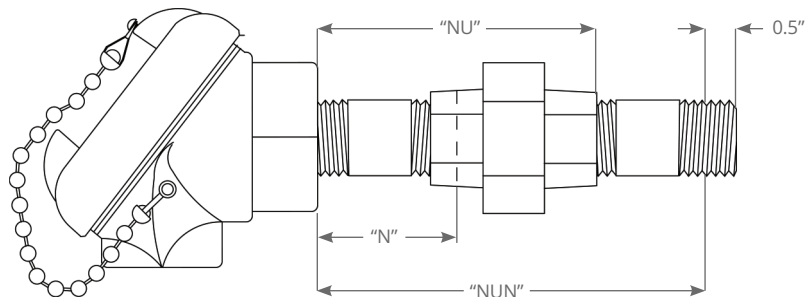

Figure 1

Part 2 - Measuring the sensor housing



- TOOLS NEEDED:**
- Tape measure
- COMPONENTS NEEDED:**
- Housing

If you are replacing a failed sensor:

- 1 Measure the existing sensor housing you are replacing to determine the length of the new housing.
- 2 Measuring from the welded tip back, mark the stainless housing.

For a new spring-loaded installation:

- 1 The overall sensor housing dimension "LL" is the sum of three numbers (See Figure 2):
 - A. the connection length (N, NU, or NUN - from Part 1)
 - B. the thermowell bore length ("L" in Fig. 2) (sometimes referred to as the "A" dimension by well manufacturers)
 - C. the insertion into the head (1.5"). Add A, B and C.
- 2 Measuring from the welded tip back, mark the stainless housing.

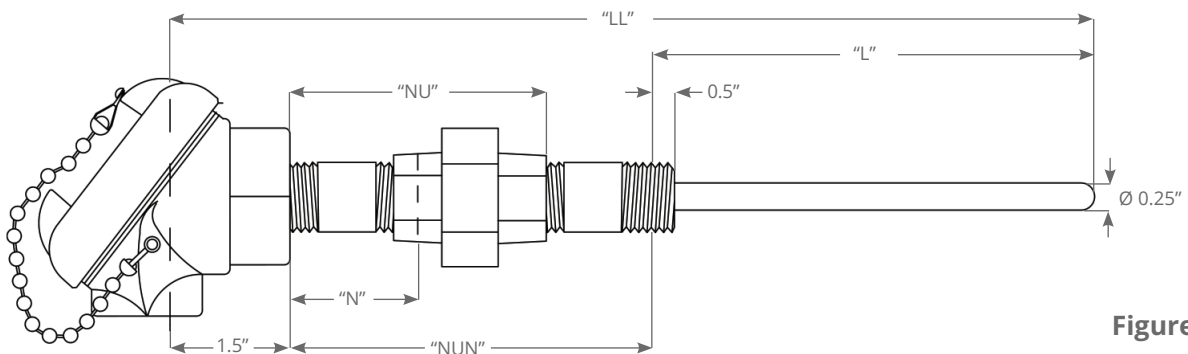

Figure 2

Part 3 - Cut the sensor housing



- TOOLS NEEDED:**
- tubing cutter
 - Vise (or crimper)
- COMPONENTS NEEDED:**
- Housing

- 1 Place the housing stock into the tube cutter, aligning the cutting wheel with the mark for housing length.
- 2 Hold the end of the housing that is to be discarded in a vise (if a vise is not available, you can use the crimp tool or vise grips to hold the housing stock).
- 3 Tighten the tube cutter blade onto the housing and with minimum pressure, rotate the tube cutter around the tube several times, tightening the cutting wheel slightly after each turn. The housing should not turn with the tubing cutter. You want to create a score through 50-75% of the wall thickness of the housing stock.



AVOID CUTTING COMPLETELY THROUGH THE HOUSING WALL. THIS CAN CLOSE THE INNER DIAMETER OF THE TUBE AND PREVENT THE POD FROM ENTERING THE HOUSING.

- 4 Loosen the cutter and remove the housing from it.
- 5 Position your thumbs on either side of the groove and gently bend the housing back and forth until it breaks. If it does not break easily do not use excessive force, but repeat the first part of the cutting procedure.
- 6 If a burr is created, remove it with the de-burring device on the tubing cutter.

Part 4 - Installing the Sensor Pod



TOOLS NEEDED:

- Crimper
- Wire cutters

COMPONENTS NEEDED:

- Cut housing
- Sensor pod
- Black plastic bushing (part #TS1092)

- 1 Select the proper pod (there are several RTD and Thermocouple options available to match your requirements.)
- 2 Insert the pod into the housing. (See Figure 3)

- 3 With the pod securely held to the bottom of the housing, crimp the housing 3" to 3 1/2" from the housing end to secure the pod in place, using the 1/4" size opening on the crimper.
- 4 Cut leadwires to approximately 3" from the end of the housing.
- 5 Slip the small black plastic bushing over the lead wires (small end first) all the way to the housing and press the bushing into the housing. This bushing is to protect the wire from chafing as it leaves the housing. If you're building a sheath with leadwire assembly, it is now complete.

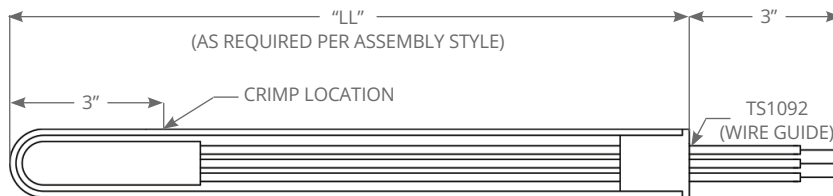

Figure 3

Part 5 - Installing the Spring-Loading Assembly



TOOLS NEEDED:

- Crimper

COMPONENTS NEEDED:

- Housing/pod assembly
- Spring-loading kit (Part # AC1087)

- 1 Slip the spring (small end first) over the lead wires. (See Figure 4)
- 2 Twist the spring clockwise onto the housing from the open end until approximately 1 1/2" of the leadwire end of the housing is exposed.
- 3 Slide the mounting plate over the lead wires and next to the spring.
- 4 Slide the transition tube over the leadwires, straight end first, and onto the housing, with the flared end flush with the leadwire end of the housing.

- 5 Slide the mounting plate over the transition tube and up against its flared end.
- 6 Keeping the flared end of the transition tube flush with the leadwire end of the housing, crimp the straight end of the transition tube to the housing, using the 5/16" hex opening on the crimper.
- 7 Twist the spring counterclockwise toward the mounting plate until the spring is holding the mounting plate snugly to the flared end of the transition tube.

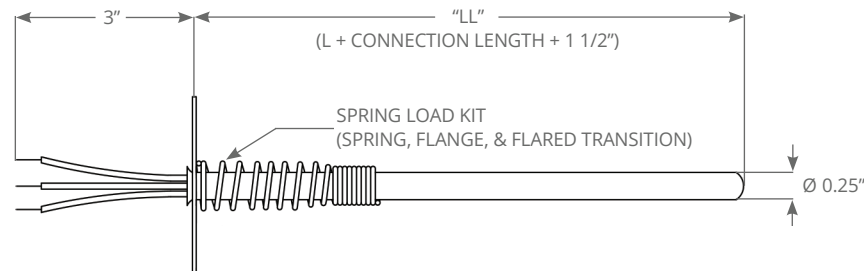

Figure 4

Part 6 - Final Sensor Assembly



TOOLS NEEDED:

- Screwdriver
- Wire strippers

COMPONENTS NEEDED:

- Spring-loaded assembly
- Terminal head assembly
- Terminal block
- 2 screws

1 Insert the spring-loaded probe assembly into the head until the mounting plate rests against the connection head.

2 Feed the lead wires through the hole in the terminal block and slide the terminal block up the wires until it rests against the mounting plate.

3 Screw the mounting screws loosely into the terminal head holding the terminal block and mounting plate.

4 Check the alignment of the assembly by pushing the housing into the head against the spring loading. When the assembly is properly aligned, tighten the screws. Do not over tighten or you will crack the ceramic terminal block.

5 Cut and strip the red wire to the appropriate length and attach it to the negative terminal. Cut the other wire (or wires) to the appropriate length and attach them to the positive terminal (terminals). (See Figure 5)



FOR THERMOCOUPLE EXTENSION LEADS TO CONTROLLER, INDICATOR OR OTHER DEVICE ONLY USE TC EXTENSION WIRE OF THE SAME CALIBRATION.

Install the temperature sensor into your process.

Recommended Practice

- A redundant device is necessary for applications where damage to the primary device could endanger life, limb or property. A high or low limit switch is necessary for applications where a dangerous runaway condition could result.

- Preventative maintenance and periodic testing is necessary for critical applications where damage could endanger property or personnel.

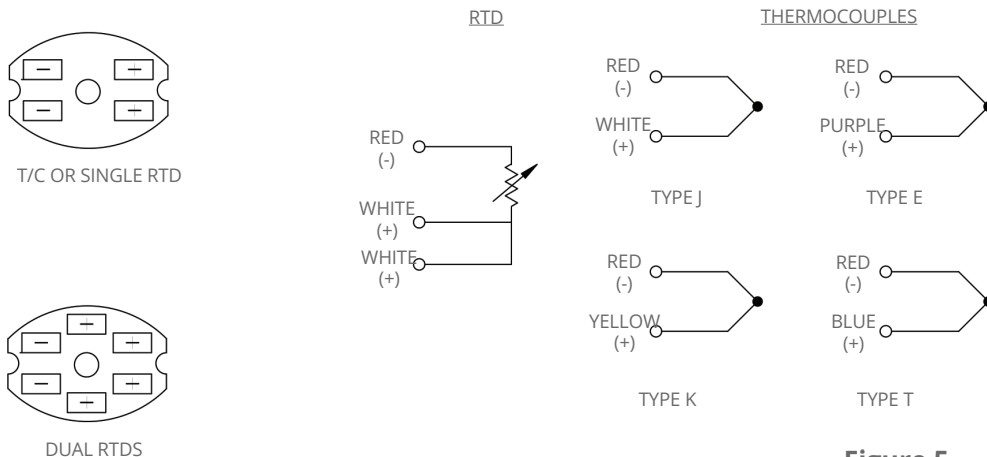

Figure 5

LIMITED WARRANTY

Seller warrants that the device hereby purchased is, upon delivery, free from defects in material and workmanship and that any such device which is found to be defective in such workmanship or material will be repaired or replaced by Seller (Ex-works, Factory, Watertown, Massachusetts. INCOTERMS); provided, however, that this warranty applies only to device found to be so defective within a period of 18 months from the date of manufacture by the Seller. Seller shall not be obligated under this warranty for alleged defects which examination discloses are due to tampering, misuse, neglect, improper storage, and in any case where devices are disassembled by anyone other than authorized Seller's representatives. EXCEPT FOR THE LIMITED WARRANTY OF REPAIR AND REPLACEMENT STATED ABOVE, SELLER DISCLAIMS ALL WARRANTIES WHATSOEVER WITH RESPECT TO THE DEVICE, INCLUDING ALL IMPLIED WARRANTIES OF MERCHANTABILITY OR FITNESS FOR ANY PARTICULAR PURPOSE.

LIMITATION OF SELLER'S LIABILITY

Seller's liability to Buyer for any loss or claim, including liability incurred in connection with (i) breach of any warranty whatsoever, expressed or implied, (ii) a breach of contract, (iii) a negligent act or acts (or negligent failure to act) committed by Seller, or (iv) an act for which strict liability will be inputted to seller, is limited to the "limited warranty" of repair and/or replacement as so stated in our warranty of device. In no event shall the Seller be liable for any special, indirect, consequential or other damages of a like general nature, including, without limitation, loss of profits or production, or loss or expenses of any nature incurred by the buyer or any third party.

UE specifications subject to change without notice.

UE UNITED ELECTRIC
CONTROLS

180 Dexter Avenue
Watertown, MA 02472 - USA
Telephone: 617 926-1000 - Fax: 617 926-2568
www.ueonline.com

FOR SENSOR BOX™ SUPPLIES AND
REPLACEMENT PARTS, PLEASE REFER TO
THE "RE-ORDER FORM" IN YOUR KIT, OR
CONSULT UE.