

SPECIFICATIONS:
 UE TYPE: J54-16009

RANGE: 30 TO 300 psi
 MAX WORKING PRESSURE: 100 psi ABOVE SET POINT
 PROOF PRESSURE: 200 psi ABOVE SET POINT,
 MAX 600 psi
 ADJUSTABLE DEAD-BAND: 10 TO 30 psi

ELECTRICAL RATING: 20A 480 VAC
 WETTED MATERIALS: ALUMINUM, BUNA-N, BRASS
 PRESSURE CONNECTION: 1/4" NPT(M)
 ADJUSTMENT TYPE: ADJUSTMENT SCREW.
 APPROVALS:
 UL LISTED, CSA CERTIFIED.
 CE COMPLIANT TO LOW VOLTAGE DIRECTIVE.

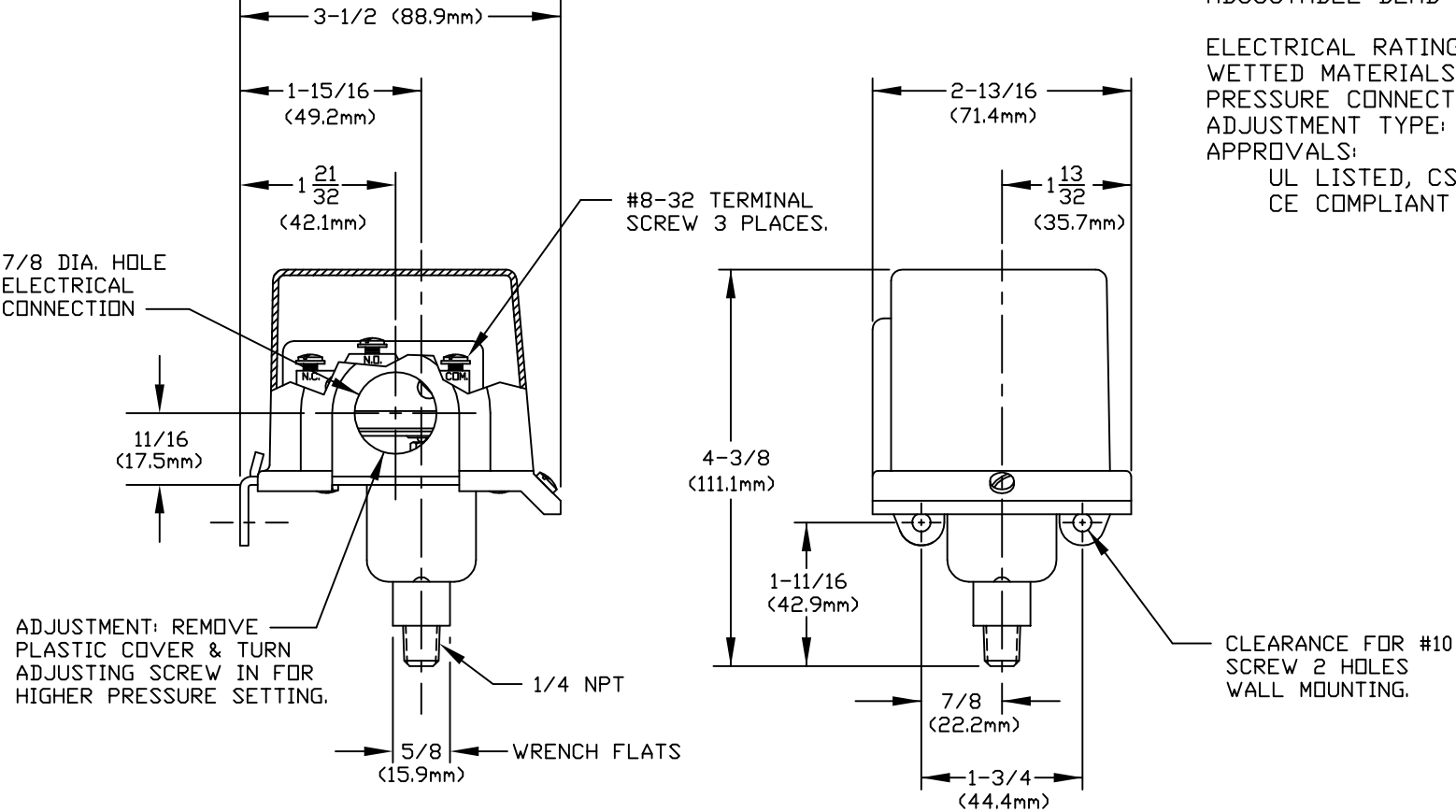

A	FIRST ISSUE. ECN# E3303	9-15-09	DWD	LK
SYM	DESCRIPTION	DATE	DWN	APPD
REVISIONS				

ORIGINAL DATE	9-15-09
DRWN	DWD
CHKD	PLW
APPD	LK
UNLESS OTHERWISE SPECIFIED DIMENSIONS ARE IN INCHES	
TOLERANCES ON FRACTIONS ±1/64	
2 PLACE DEC 3 PLACE DEC ANGLES ±.010 ±.005 ±1/2°	
DO NOT SCALE THIS DRAWING	

TITLE	J54-16009
SCALE	HALF

DF001
REV. B

UNITED ELECTRIC
 CONTROLS COMPANY
 WATERTOWN * MASSACHUSETTS

DWG NO
 A-13956