



## 117 Series

**Type H117  
(Pressure Switch)**  
**Type H117K  
(Differential Pressure Switch)**



UNITED ELECTRIC  
CONTROLS

## Installation and Maintenance Instructions

Please read all instructional literature carefully and thoroughly before starting. Refer to the final page for the listing of Recommended Practices, Liabilities and Warranties.

### GENERAL



BEFORE INSTALLING, CHECK THE SENSOR MODEL SELECTED FOR COMPATIBILITY BETWEEN THE PROCESS MEDIA AND THE SENSOR AND WETTED PARTS.



MISUSE OF THIS PRODUCT MAY CAUSE EXPLOSION AND PERSONAL INJURY. THESE INSTRUCTIONS MUST BE THOROUGHLY READ AND UNDERSTOOD BEFORE UNIT IS INSTALLED.



**UL** THIS EQUIPMENT IS SUITABLE FOR CLASS I, DIVISION 2, GROUPS A,B,C,D; CLASS II, DIVISION 2, GROUPS F AND G; CLASS III; OR NON-HAZARDOUS LOCATIONS ONLY.

The 117 series pressure and differential pressure switch utilizes a bellows or diaphragm sensor to detect a pressure change. The response, at a pre-determined set point, actuates a SPDT or DPDT snap-acting switch, converting the pressure signal into an electrical signal. Control set point may be varied by turning the internal adjustment hex. (see adjustment-Part II.)



PROOF PRESSURE\* LIMITS STATED IN THE LITERATURE AND ON NAMEPLATES MUST NEVER BE EXCEEDED, EVEN BY SURGES IN THE SYSTEM. OCCASIONAL OPERATION OF UNIT UP TO PROOF PRESSURE IS ACCEPTABLE (E.G., START-UP, TESTING). CONTINUOUS OPERATION SHOULD NOT EXCEED THE DESIGNATED OVER RANGE PRESSURE.

#### \*PROOF PRESSURE

THE MAXIMUM PRESSURE TO WHICH A PRESSURE SENSOR MAY BE OCCASIONALLY SUBJECTED, WHICH CAUSES NO PERMANENT DAMAGE (E.G., START-UP, TESTING). THE UNIT MAY REQUIRE RE-GAPPING.



WARNING: EXPLOSION HAZARD. THESE PRODUCTS DO NOT HAVE ANY FIELD REPLACEABLE PARTS. ANY SUBSTITUTION OF COMPONENTS MAY IMPAIR SUITABILITY FOR CLASS I, DIVISION 2.

Please refer to product bulletin for product specifications. Product bulletins may be found at [www.ueonline.com](http://www.ueonline.com).

## Part I - Installation

**Tools Needed**  
Adjustable Wrench  
Screwdriver  
Hammer (for alternate wire knockouts)

### MOUNTING



WARNING: EXPLOSION HAZARD - DO NOT DISCONNECT EQUIPMENT UNLESS POWER HAS BEEN SWITCHED OFF OR THE AREA IS KNOWN TO BE NON-HAZARDOUS.



INSTALL UNIT WHERE SHOCK, VIBRATION AND TEMPERATURE FLUCTUATIONS ARE MINIMAL. MOUNT UNIT SO THAT MOISTURE IS PREVENTED FROM ENTERING THE ENCLOSURE. IF UNIT IS BEING INSTALLED WHERE HEAVY CONDENSATION IS EXPECTED, VERTICAL MOUNTING (PRESSURE CONNECTION DOWN) IS REQUIRED. DO NOT MOUNT IN AMBIENT TEMPERATURES EXCEEDING PUBLISHED LIMITS.



ALWAYS HOLD A WRENCH ON THE PRESSURE HOUSING HEX WHEN MOUNTING UNIT. DO NOT TIGHTEN BY TURNING ENCLOSURE. THIS WILL DAMAGE SENSOR AND WEAKEN SOLDERED OR WELDED JOINTS.

Controls may be mounted and operated in any position. They may be surface mounted via the two mounting ears on either side of the enclosure, or directly to a rigid pipe by using the pressure connection. Low pressure and differential pressure units, models 520-535, 540-548, are also available with an optional surface mounting bracket. Should the control be installed where condensation is expected, vertical mounting is recommended as a means of keeping water away from switch terminals.

### WIRING



DISCONNECT ALL SUPPLY CIRCUITS BEFORE WIRING UNIT. WIRE UNITS ACCORDING TO NATIONAL AND LOCAL ELECTRICAL CODES. MAXIMUM RECOMMENDED WIRE SIZE IS 14 AWG. THE RECOMMENDED TIGHTENING TORQUE FOR FIELD WIRING TERMINALS IS 7 TO 17 IN-LBS. USE 75°C RATED COPPER CONDUCTORS ONLY.



ELECTRICAL RATINGS STATED IN LITERATURE AND ON NAMEPLATES MUST NOT BE EXCEEDED. OVERLOAD ON A SWITCH CAN CAUSE FAILURE ON THE FIRST CYCLE.

Remove the two screws retaining the cover and cover gasket. A 1/2" NPT conduit connection is provided on the left hand side of the enclosure. Two cast-in 7/8" diameter knockouts for electrical conduit are located on the side and back of enclosure (see dimensional drawings, opposite page). These can easily be knocked out by placing a blade of a screwdriver in groove and tapping sharply with a hammer. The terminal block terminals are clearly labeled "Common", "Normally Open" and "Normally Closed". For units supplied with DPDT, all terminals are labeled and the following color code applies.

	SPDT	DPDT	
		SWT1	SWT2
Common	Violet	Violet	Yellow
Normally Closed	Black	Black	Red
Normally Open	Blue	Blue	Orange

Grounding screw and clamp (cast in symbol) are provided. Keep the wire as short as possible to prevent interference with the plunger.

# Part II - Adjustments

### Tools Needed

5/8" Open End Wrench



ALL MODELS HAVE A TWO-PIECE ADJUSTABLE PLUNGER (SEE FIGURE 1). THIS FEATURE IS CHARACTERIZED BY A 3/16" HEX HEAD SCREW INSTALLED IN THE 1/4" HEX PLUNGER. THE LENGTH OF THIS ASSEMBLY IS ADJUSTED AT OUR FACTORY AND IS CRITICAL TO THE FUNCTION OF THE CONTROL. DURING NORMAL ADJUSTMENT, THESE COMPONENTS SHOULD NOT BE DISTURBED.

### Adjustment Procedure for H117, H117K

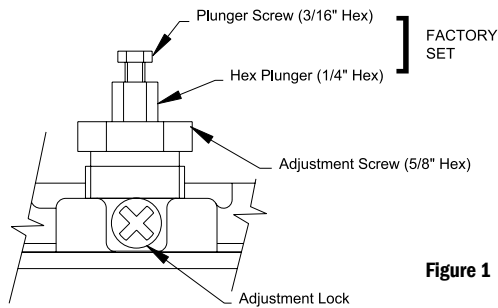

Figure 1

For set point adjustments and recalibration, connect control to a calibrated pressure source.

Remove pressure switch cover. Adjust set point by turning 5/8" hex adjustment screw clockwise (left) to raise set point, or counter-clockwise (right) to lower set point. Secure adjustment screw by tightening adjustment lock (see dimensional drawings.) Controls include uncalibrated reference scales for high, low or mid range settings.

**NOTE:** Models 190-194 and 490-494 (welded stainless steel diaphragms). These models are application sensitive. For rising pressure applications, set point should be adjusted from low pressure up to set point. For falling pressure applications set point should be adjusted from high pressure down to set point. Wide pressure cycling above and below set point can cause control band shift.

## RE-GAPPING PROCEDURE

### Tools Needed

5/8" Open End Wrench

3/16" Open End Wrench

1/4" Open End Wrench



GAPPING IS FACTORY-SET AND CRITICAL TO THE FUNCTION OF THE SWITCH. THIS PROCEDURE SHOULD ONLY BE PERFORMED IF THE PLUNGER HAS ACCIDENTALLY BEEN ADJUSTED.

1. Loosen adjustment lock.
2. Turn 5/8" hex adjustment screw clockwise (left), to approximately mid range. This puts a load on the sensor and exposes the plunger flats. Using a 1/4" wrench on the plunger and a 3/16" wrench on the plunger hex screw, turn hex screw counter clockwise (right) from plunger until switch actuates. If switch is already actuated, turn plunger hex screw clockwise (left), until switch deactuates. Turn hex screw clockwise (left) from this point. (see chart below for Flats and approximate Gap.)
3. Check set point according to Part II Adjustments.
4. Connect wires and replace cover securely.

Models	Flats	Approx. Gap
171-174	2-2 1/2	.0085 to .0105"
183-194	1-1 1/2	.004 to .006"
483-494	1-1 1/2	.004 to .006"
358-376	5-6	.020 to .025"
700-706	3 1/2 - 4	.014 to .017"
521-525	2-2 1/2	.0085 to .0105"
531-535	2-2 1/2	.0085 to .0105"
540-548	2-2 1/2	.0085 to .0105"
560-567	1-1 1/2	.004 to .006"

## Dimensions

Dimensional drawings for all models may be found at [www.ueonline.com](http://www.ueonline.com).

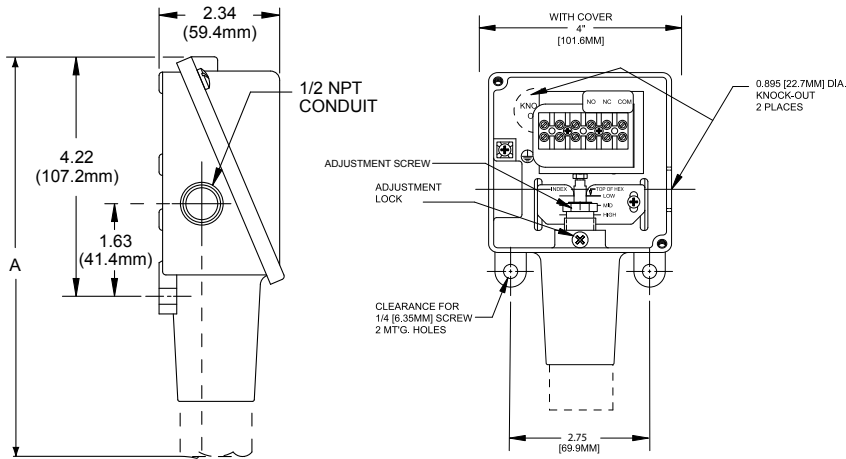

**H117, H117K**

COVER REMOVED IN FRONT VIEW

## Dimension A

Models	Inches	mm	NPT
171-174	7.63	193,7	1/2"
183-186	7.56	192,1	1/2"
188, 189	6.63	168,4	1/2"
190-194	6.63	168,4	1/2"
218	6.56	166,7	1/4"
358-376	7.00	177,8	1/4"
483-486	7.56	192,1	1/2"
488, 489	6.63	168,4	1/2"
490-494	6.63	168,4	1/2"
520-525	8.44	214,4	1/2"
530-535	8.00	203,2	1/2"
540-543	8.47	215,0	1/8"
544-548	8.53	216,6	1/8"
560-564	6.63	168,4	2" Sanitary fitting
565-567	6.63	168,4	1-1/2" San. fitting
700-706	6.63	168,3	1/4"

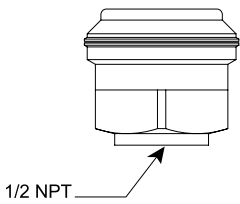

**Models 171-174**

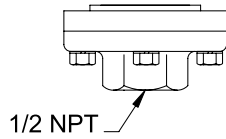

**Models 183-186, 483-486**

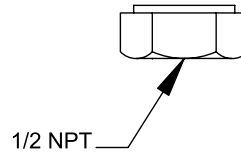

**Models 188-194, 488-494**

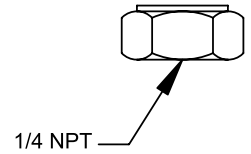

**Models 218, 358-376, 700-706**

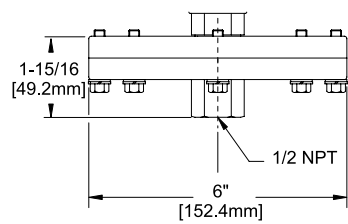

**Models 520-525**

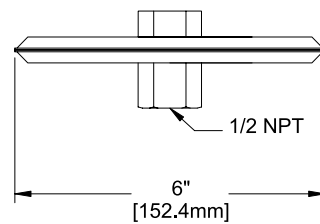

**Models 530-535**

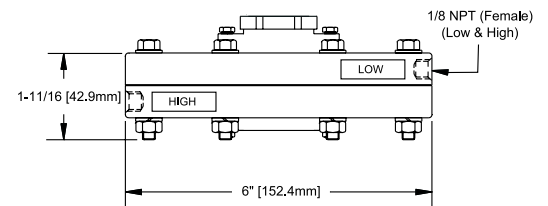

**Model 540-543**

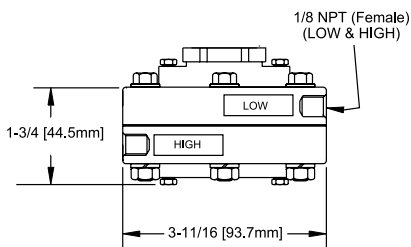

**Models 544-548**

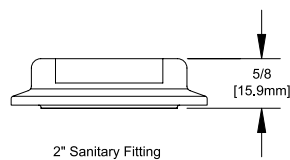

**Models 560-564**

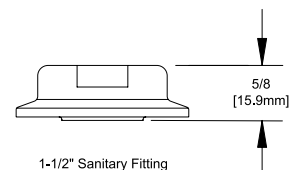

**Models 565-567**

## RECOMMENDED PRACTICES AND WARNINGS

United Electric Controls Company recommends careful consideration of the following factors when specifying and installing UE pressure and temperature units. Before installing a unit, the Installation and Maintenance instructions provided with unit must be read and understood.

- To avoid damaging unit, proof pressure and maximum temperature limits stated in literature and on nameplates must never be exceeded, even by surges in the system. Operation of the unit up to maximum pressure or temperature is acceptable on a limited basis (e.g., start-up, testing) but continuous operation must be restricted to the designated adjustable range. Excessive cycling at maximum pressure or temperature limits could reduce sensor life.
- A back-up unit is necessary for applications where damage to a primary unit could endanger life, limb or property. A high or low limit switch is necessary for applications where a dangerous runaway condition could result.
- The adjustable range must be selected so that incorrect, inadvertent or malicious setting at any range point cannot result in an unsafe system condition.
- Install unit where shock, vibration and ambient temperature fluctuations will not damage unit or affect operation. When applicable, orient unit so that moisture does not enter the enclosure via the electrical connection. When appropriate, this entry point should be sealed to prevent moisture entry.
- Unit must not be altered or modified after shipment. Consult UE if modification is necessary.
- Monitor operation to observe warning signs of possible damage to unit, such as drift in set point or faulty display. Check unit immediately.
- Preventative maintenance and periodic testing is necessary for critical applications where damage could endanger property or personnel.
- Electrical ratings stated in literature and on nameplate must not be exceeded. Overload on a switch can cause damage, even on the first cycle. Wire unit according to local and national electrical codes, using wire size recommended in installation sheet.
- Do not mount unit in ambient temp. exceeding published limits.

## LIMITED WARRANTY

Seller warrants that the product hereby purchased is, upon delivery, free from defects in material and workmanship and that any such product which is found to be defective in such workmanship or material will be repaired or replaced by Seller (Ex-works, Factory, Watertown, Massachusetts. INCOTERMS); provided, however, that this warranty applies only to equipment found to be so defective within a period of 24 months from the date of manufacture by the Seller. Seller shall not be obligated under this warranty for alleged defects which examination discloses are due to tampering, misuse, neglect, improper storage, and in any case where products are disassembled by anyone other than authorized Seller's representatives. EXCEPT FOR THE LIMITED WARRANTY OF REPAIR AND REPLACEMENT STATED ABOVE, SELLER DISCLAIMS ALL WARRANTIES WHATSOEVER WITH RESPECT TO THE PRODUCT, INCLUDING ALL IMPLIED WARRANTIES OF MERCHANTABILITY OR FITNESS FOR ANY PARTICULAR PURPOSE.

## LIMITATION OF SELLER'S LIABILITY

SELLER'S LIABILITY TO BUYER FOR ANY LOSS OR CLAIM, INCLUDING LIABILITY INCURRED IN CONNECTION WITH (I) BREACH OF ANY WARRANTY WHATSOEVER, EXPRESSED OR IMPLIED, (II) A BREACH OF CONTRACT, (III) A NEGLIGENT ACT OR ACTS (OR NEGLIGENT FAILURE TO ACT) COMMITTED BY SELLER, OR (IV) AN ACT FOR WHICH STRICT LIABILITY WILL BE INPUTTED TO SELLER, IS LIMITED TO THE "LIMITED WARRANTY" OF REPAIR AND/OR REPLACEMENT AS SO STATED IN OUR WARRANTY OF PRODUCT. IN NO EVENT SHALL THE SELLER BE LIABLE FOR ANY SPECIAL, INDIRECT, CONSEQUENTIAL OR OTHER DAMAGES OF A LIKE GENERAL NATURE, INCLUDING, WITHOUT LIMITATION, LOSS OF PROFITS OR PRODUCTION, OR LOSS OR EXPENSES OF ANY NATURE INCURRED BY THE BUYER OR ANY THIRD PARTY.

*UE specifications subject to change without notice.*



UNITED ELECTRIC  
CONTROLS

180 Dexter Avenue, P.O. Box 9143  
Watertown, MA 02471-9143 USA  
Telephone: 617 926-1000 Fax: 617 926-2568  
<http://www.ueonline.com>